



# Integrating Gender

# And

# Development

IN LOCAL LEGISLATION  
AND POLICY FORMULATION



A Joint Project of the Department of the Interior and Local Government  
and the National Commission on the Role of Filipino Women with the  
support of the Canadian International Development Agency (CIDA)

# **TABLE OF CONTENTS**

---

*Introduction*

*Messages*

*Acknowledgment*

*Foreword*

Training Overview .....	1-20
Manifestations of Gender Bias.....	21-41
Personal Reflections.....	42-46
Conceptual Framework .....	47-64
Women and Governance.....	65-78
Legal Mandates for Gender and Development.....	79-95
Tools for Analyzing Community Issues .....	96-115
Gender Responsive Local Legislation and Policy Formulation.....	116-147
Drafting of Ordinances and Executive Issuances.....	148-153
Guide to Planning.....	154-156
Training Plan.....	157-169
Matrices	

---

## INTRODUCTION

---

*This publication on Local legislation and Policy Formulation on Gender and Development is the result of the concerted effort of the Department of the Interior and Local Government, the National Commission on the Role of Filipino Women and the Canadian International Development Agency, the funding institution, to provide the Local Government Units (LGUs) a training tool on the mechanics and strategies of integrating GAD concepts and principles in their ordinances, resolutions and policies.*

*A step-by-step guide in administering the training is comprehensively presented in this publication to ensure that the gender development concepts and principles are internalized by the participating local officials and employees at the end of the training course.*

*This publication consists of eleven (11) modules, starting with the presentation of the objectives and components of the training course. It ends up with a module designed to assist participants in crafting ordinances, resolutions or policies that are both gender-sensitive and gender-responsive.*



---

## M E S S A G E

---

*My congratulations to the Project Management Team of the Component on Integrating Gender and Development in the Local Legislation and Policy Formulation Modules of the DILG under the Institutional Strengthening Project (ISP) II of the Canadian International Development Authority (CIDA). I also take this opportunity to thank the National Commission on the Role of Filipino Women (NCRFW) which had shepherded this undertaking to its completion.*

*Since 1992, this Department has endeavored to mainstream GAD into its operations in line with Republic Act No. 7192 or the Women in Development and Nation-Building Act and other related laws.*

*Although the status of women and men is not solely determined by law, it is clear that proactive legislations at the local level are essential in pursuing their interest and welfare. Thus, the Department of the Interior and Local Government aspires that the development of gender-responsive policies at the LGUs is marked by a concerted effort at giving women a voice and an active participation in their decision-making and policy-making activities.*

*It is hoped that this Manual will serve as our general guide in responding to the need for continued advocacy for more gender-responsive local ordinances and policies. It is likewise hoped that its continued usage will match the zeal and enthusiasm of GAD advocates and practitioners and finally lead to the levelling of the playing field for women and men at the local government units.*

✓  
**HON. JOSE D. LINA, JR.**  
Secretary



## MESSAGE

*The National Commission on the Role of Filipino Women (NCRFW) commends DILG's commitment to support the gender-mainstreaming efforts of local government units. Being at the forefront of promoting gender equality in local governance, the DILG continues to enhance the capacity of LGUs to respond to gender issues of their locality.*

*In partnership with the NCRFW, this manual on gender responsive local legislation and policy formulation was developed to capacitate DILG frontline workers in integrating gender in the area of policy formulation and local legislation.*

*The Commission has noted pioneering efforts of several LGUs in coming up with gender-responsive local legislation such as the passage of local Gender and Development (GAD) codes. We envision that through this tool and the continuing support of the DILG, gender-responsive local legislations shall be in place in all LGUs, thereby ensuring that gender issues are prioritized as legislative agenda.*

*Our appreciation to DILG Assistant Secretary for Administration and Human Resource Development (OASHRD) who led in developing this tool. May its pursuit in enhancing its organizational capacity to assist LGUs on gender-mainstreaming serve as an inspiration to all who want to make transformation a reality.*

**AURORA JAVATE-DE DIOS**  
NCRFW Chairperson



---

## ACKNOWLEDGMENT

---

*These training modules would not have been possible were it not for the funding support of the Canadian International Development Authority (CIDA) and the combined effort of the National Commission on the Role of Filipino Women (NCRFW) and the Department of the Interior and Local Government.*

*Worthy to mention are the comments and technical inputs provided by our guest participants from selected LGUs and by our own field officers — the Local Legislation Specialists and Regional GAD Focal Points during our technical review sessions. Their inputs greatly helped us in coming up with these important documents.*

*The expertise of the project consultants from the Sentro ng Alternatibong Lingap Panlegal (SALIGAN) and some nationally known GAD experts, not to forget the invaluable support of Ms. Lorraine B. Villacorta and former DILG Assistant Secretary Remedios A. Paralejas, enabled us to produce these quality training modules.*

*Likewise, the cooperation and support of the Project Management Office and the Team on Integrating GAD in the Local Legislation and Policy Formulation Modules of the DILG deserve special commendation. Their demonstrated interest and selfless efforts contributed much to the completion of this work.*

*To all of them, congratulations and **MABUHAY!***

**AUSTERE A. PANADERO**

Assistant Secretary for Administration and  
Human Resource Development/  
Chairperson, DILG GAD Focal Pt.

---

## **F O R E W O R D**

---

*This Manual on Integrating Gender and Development in the Local Legislation and Policy Formulation Modules of the DILG is a product of a year-long collaboration between the Department of the Interior and Local Government (DILG) and the National Commission on the Role of Filipino Women (NCRFW) under the Institutional Strengthening Project (ISP) of the Canadian International Development Authority (CIDA). With the end in view of developing the capabilities of our frontline workers to push the Department's mandate to capacitate the LGUs in formulating operational policies and legislation that are gender-sensitive and responsive, this document primarily addresses gender issues and concerns in both legislative and management/operational policies of the LGUs. These may relate to data disaggregation, personnel recruitment, assignment and promotion, training, collaboration with non-government organizations or NGOs, project identification and other related endeavors that will institutionalize GAD in the overall development framework of the LGUs.*

*This Manual provides a general guide to DILG fieldmen in transferring technology to the LGUs following these modules:*

- I. Gender Sensitivity Training*
- II. Conceptual Framework on Gender-Responsive Legislation and Policy Formulation*
- III. Legal Mandates*
- IV. Tools for Gender Analysis*
- V. Gender-Responsive Local Legislation*
- VI. Ordinance and Executive Issuance Drafting*
- VII. Action Planning*

*As the oversight agency that is entrusted with the task of formulating guidelines to ensure that LGUs and agencies under their supervision are gender-responsive, the DILG is positive that the goal of providing both women and men equal opportunity in contributing and sharing the gains of development can be fully attained.*

# ***Training Overview***

---

## **Introduction**

This session presents the training objectives, components and design. It also serves to introduce the participants and their respective expectations from the training.

## **Rationale**

The session aims to give a clear overview of the training and the topics to be covered. It also allows the participants to express their expectations from the training. Furthermore, the session is designed to unfreeze the participants and set an open and interactive atmosphere for the whole training.

## **Objectives**

At the end of the session, the participants should be able to:

- ↳ get to know the facilitators and the other participants;
- ↳ give their expectations from the training (in terms of content and methodology), facilitators, and co-participants; and
- ↳ know the training objectives and design.



## Activity 1

: Introduction of the Facilitators and Participants, and Surfacing of Expectations (1 hour and 15 minutes)

**Methodology to be used:** Game (*Bangka at Sagwan*)

### Instructions:

1. Begin the session with the introduction of the training facilitators.
2. The introduction of the participants follows. This will be done through an activity called *Bangka at Sagwan*. Distribute cut-out drawings of either *bangka* or *sagwan* to each of the participants. Each participant should have one cut-out drawing, which may either be a *bangka* or *sagwan*.
3. Explain to the participants that each cut-out drawing of a *bangka* has the name of a province printed on it. On the other hand, each piece of cut-out drawing of a *sagwan* has the name of a capital city or municipality. The object of the game is to find the matching pair of a *bangka*, with the printed name of a province, and a *sagwan*, with the name of the corresponding capital city or municipality of the said province.

4. Instruct the participants to look for the person holding the *bangka* or *sagwan* that matches the cut-out drawing of what s/he has picked. Once they found their respective partners, individual participants introduce themselves and share their expectations from the training, from the facilitators and from the co-participants.
5. The participants then assemble in plenary. Each participant introduces his/ her partner and states his/ her partner's expectations. The one who was introduced in turn introduces his/ her partner.
6. The trainer writes down the expectations on the board and groups these according to their categories, i.e., on the contents of the training, methodology, the facilitators and the co-participants.
7. After all the participants have spoken, go through each expectation, discussing those that are not very clear. For the expectations from the facilitators, present your response to each. For expectations from co-participants, ask the participants if they will be able to favorably respond to each expectation. By way of responding to the expectations from the content and methodologies of the training, go to the next activity, i.e. presentation of the training objectives and the seminar design.

## **Materials Needed**

- Cut-out drawings of *bangka* and *sagwan* corresponding to the number of participants. Each pair of *bangka* and

sagwan should be printed with the name of a province and its capital or municipality.

The drawings should be placed on a hard board, preferably a cartolina or an illustration board. Preferred size is 8½ inches x 5½ inches. An illustration of the envisioned drawings is shown below:



Zamboanga del Sur



Pagadian City

## Activity 2

Presentation of Training Objectives and Seminar Design (30 minutes)

**Methodology to be used:** Presentation and discussion

### Instruction:

Present the training objectives and design preferably through the use of acetates and overhead projector (OHP)

### Discussion Points:

1. The primary objective of the training is to capacitate the participants in formulating operational policies and legislation that are gender-sensitive and responsive.

2. The specific objectives of the training are:

- ↳ For the participants to arrive at a common understanding and appreciation of GAD-mainstreaming;
- ↳ For the participants to understand their roles as local legislators and local government officials in integrating gender in local legislation and policy formulation, and
- ↳ For the participants to appreciate and apply the tools for gender analysis in aid of gender-responsive legislation and policy formulation.

3. The Training Design shall be:

**Day One**

Introduction	8:30 – 10:00
Sex and Gender	10:00 – 12:00
Manifestations of Gender Bias	1:30 – 4:00
Personal Reflection	4:00 – 6:00

**Day Two**

Recapitulation	8:30 – 9:00
Conceptual Framework	9:00 – 10:30
Women and Governance	
Intro to Governance (Nat'l & Loc)	10:30 – 12:00
Legal Mandates for GAD	1:00 – 2:00
Tools for Gender Analysis	2:00 – 4:30
Gender-Responsive Local Leg. (on principles in local legislation)	4:30 – 6:00

## **Day Three**

Recapitulation	8:30 – 9:00
Local Legislation (cont. on procedure, advocacy & forms)	9:00 – 12:00
Workshop: Drafting of ordinance and executive issuance)	1:00 – 3:00
Mini-Plenary	3:00 – 5:00
Main Plenary	5:00 – 6:00

## **Day Four**

Recapitulation	8:30 – 9:00
Planning	9:00 – 10:30
Evaluation	10:30 – 11:00
Closing	11:00 – 12:00

## **Materials Needed**

- OHP
- Acetate

## Acetate 1:

The *primary objective* of the training is to capacitate the participants in formulating operational policies and legislation that are gender-sensitive and responsive.

The *specific objectives* of the training are:

1. For the participants to arrive at a common understanding and appreciation of GAD mainstreaming.
2. For the participants to understand their roles as local legislators and local government officials in integrating gender in local legislation and policy formulation.
3. For the participants to appreciate the tools for gender analysis, in aid of gender-responsive legislation and policy formulation.

## Acetate 2:

### Schedule of Activities

#### Day One

Introduction	8:30 – 10:00
Sex and Gender	10:00 – 12:00
Manifestations of Gender Bias	1:30 – 4:00
Personal Reflections	4:00 – 6:00

#### Day Two

Recap	8:30 – 9:00
Conceptual Framework	9:00 – 10:30
Women and Governance	
Intro to Governance (Nat'l & Loc)	10:30 – 12:00
Legal Mandates for GAD	1:00 – 2:00
Tools for Gender Analysis	2:00 – 4:30
Gender Responsive Local Legislation (on principles in local legislation)	4:30 – 6:00

#### Day Three

Recap	
Local Legislation (cont.) (on procedure, advocacy & forms)	9:00 – 12:00
Workshop: Drafting of ordinance and executive issuance	1:00 – 3:00
Mini-Plenary	3:00 – 5:00
Main Plenary	5:00 – 6:00

#### Day Four

Recap	8:30 – 9:00
Planning	9:00 – 10:30
Evaluation	10:30 – 11:00
Closing	11:00 – 12:00

# ***Sex and Gender***

---

## **Introduction**

This session marks the formal start of the training. The topics that will be taken up are basic concepts that the participants need to clearly understand in order to be able to craft gender-responsive legislation and executive issuances.

## **Rationale**

Women are often marginalized from economic activities and benefits and are subordinate to men when it comes to decision-making processes. This is true in both the household and in other societal structures (e. g community). More often than not, women are relegated to be supporters of men, and not their equal partners. This unequal relations is mostly rooted in the socially constructed notions of men and women's roles and capabilities.

The session is designed to surface the participants' understanding and appreciation of these social constructs, and to present the view that what are often considered "natural" differences between women and men are actually learned behavior that are passed on from generation to generation through socialization. These social constructs of what are considered feminine and masculine have constricted women and men to do roles that are expected of them. Unfortunately, because of their reproductive function, women have been relegated to take a lower position vis-a-



vis men. Women are expected not only to give birth but also to take care of the children and to take charge of the household concerns. Men, on the other hand, are expected to work outside of the home and bring income for the sustenance of the family. As breadwinners, they are also considered heads of the households and are given the upper hand in decision-making processes in the household and in society as a whole.

In order to clarify the social constructs regarding gender roles, basic concepts of sex, gender and sexual division of labor must be surfaced in this session. Clearer appreciation of these basic concepts will result in a more sensitive analysis of issues and a more holistic frame of responses that can truly benefit the men and women in the communities.

## Objectives

At the end of the session, the participants should be able to:

- ↳ define sex and gender and understand the distinctions between the two, and
- ↳ understand the impact of sexual division of labor on gender relations.

## Core Messages

1. What are usually thought of as natural differences between women and men are actually social constructs

that are human-made and learned values and behavior, and can in fact, be unlearned and changed.

2. Most of the commonly considered "natural" gender-based differences are often used in discriminating against women.
3. Development agenda and projects that aim to push for gender equality and empowerment should address the unequal power relations that have relegated women to secondary roles in society.

### **Activity 3**

: Characteristics of men and women differ based on biology and culture (30 minutes)

**Methodology to be used:** Game (Word Association)

### **Instructions:**

1. Introduce the session by saying that it is important to get a sense of the group's level of understanding of basic concepts that will be discussed in this training. Before the group can proceed to discuss gender-responsive legislation-making and issuing gender-fair policies, it is imperative that the group levels off on some fundamental ideas that will form the bases of the kind of legislation or executive acts that should be issued by local government units.
2. State that the first session will start with a game on word association.

### 3. Explain the mechanics of the game:

- ↳ Divide the participants into groups of ten. With about 30 participants, no more than three groups should be formed.
  - ↳ All teams will be asked to form a line facing the board.
  - ↳ Each team is provided with a white board marker, chalk or pentel pen.
  - ↳ The facilitator will say a word and each participant will write on the board the first word/ words they associate it with. Individual participants will take turns in writing. Once finished, the participant will pass the marker to the next teammate while s/he goes to the end of the line.
  - ↳ All members of the team should be given at least one chance to write on the board.
  - ↳ Each team will be given two minutes to write all their answers on the board. No description, word or phrase can be repeated by the members in each team. The teams can have another round of answers if there is still time left.
4. The first word that the trainer will ask the participants to describe is "man" (*lalaki*)
5. After the first two minutes, the second word that will be described is "woman" (*babae*)

6. With all the descriptions given by all participants now written on the board, quickly read each answer to make sure that there is a common understanding of the words as written. If the words written are vague, be sure to ask the person who wrote the word what it means. This way, the group will understand what the writer exactly means.
7. After going through all the descriptions written for "man" and "woman", interchange the headings for each set of answers. The heading man/male will now be woman/female and vice-versa.
8. Ask participants whether the same descriptions hold true with the interchanged headings.
9. Go through each description and ask the participants if the words can apply to the reversed headings.
10. The participants are expected to agree that all descriptions can be interchanged, except for those referring to the anatomical/ biological parts of men and women. This is to be the take-off point for the lecture on sex and gender.
11. This activity aims to highlight the following points: Only the physical attributes of men and women cannot be interchanged (i.e. women have uterus and ovaries; they bear children; men have penises and testicles and cannot bear children). The other characteristics or descriptions of men and women can be interchanged (i.e. they can be both loyal, niggers or good cooks). The first set of characteristics covers the concept of sex; the second, gender.

*(Source: Harnessing Self-Reliant Initiatives and Knowledge, Inc., Gender Sensitivity Training for Men)*

## **Activity 4**

: Distinction between Sex and Gender  
(1 hour, 30 minutes)

**Methodology to be used:** Lecture-Discussion

### **Discussion Points:**

1. The lecture should highlight the following:

- ↳ Distinctions between sex and gender
- ↳ Sexual division of labor: productive and reproductive work
- ↳ Imbalance in power relations/ gender bias

#### Definition of Sex

- Sex relates to human biology, referring to permanent differences in biological and physical conditions between men and women.
- Physical conditions refer to different hormonal and chromosomal make-up, internal and external genitalia, as well as secondary sex characteristics.
- These differences are natural, universal and permanent in all cultures and throughout history.

#### Definition of Gender

- Gender refers to socially and culturally ascribed roles, practices, attitudes and values that characterize males as masculine and females as feminine.

- Gender is not constant; it varies in time and history, place, social class, economic circumstance, ethnicity or age.

2. What may be considered as assigned work for men and women varies from culture to culture.

- ↳ In India or Pakistan, construction work is done by women because they are low-paying jobs. In the Philippines, only men work in construction. In some South Pacific cultures, men are passive participants in romantic relations. They wait for the women to show expression of love.

Society assigns and identifies roles, activities and behaviors for men and women. Through the process of socialization, these assigned roles, behaviors, etc. are reinforced in society. These learned behaviors become the acceptable and normal indicators of being masculine or feminine.

The assignment of roles, behaviors and traits happen from conception. In the Philippines, people speculate on the sex of the unborn child based on the mother's appearance (e.g. girl if she is "blooming" and boy if not), or the shape of her belly (girl if the belly is rounder, boy if not). As soon as the child is born, he will be clothed in blue and she will be wrapped in pink. As they grow older, boys are taught what are male/masculine traits (e.g. not prone to crying, strong, leader), while girls are taught female/feminine traits (e.g. sensitive, fickle minded, follower). Toys and games reinforce these roles in the young minds of children. Thus, boys play with guns, cars, doctor's

kit while girls play with dolls, beauty or cooking kits. These roles define the different levels of relationships that men and women will have in their lives.

### 3. Sexual Division of Labor or the Productive/ Reproductive Divide

Society's delineation of male and female roles can be classified as productive, reproductive and community work. This is also called the sexual division of labor. Men are assigned the productive role, as breadwinner of the family. Women are "tasked" with the reproductive role: to bear children and maintain the home. While both perform community work, men take on lead roles while women do volunteer work

↳ *Reproductive Work.* The marginalization of women is mainly an offshoot of the perspective called biological determinism. It upholds the belief that because the reproductive system is by nature a characteristic of the female sex, women's physical make-up is consequently more delicate.

Reproductive work generally relates to child-bearing and child care. Because women possess the sole capacity to bear children, they are considered as the natural persons to take on child care and child-rearing functions. This makes them the logical caretakers of the home, producing the "woman's place is in the domestic sphere while men dominate the public arena" perception, a distinction that has an immense impact on the overall development of women and men. Reproductive work is unpaid and is not

considered an input in the determination of the country's economic activities at any given time.

As the presumed sole caretakers of the home, women have been assigned to jobs that are regarded largely as extensions of their domestic roles – i.e., nurses, teachers, secretaries, midwives, social workers, salesgirls, entertainers and housemaids. These jobs have comparatively lower status and compensation than those traditionally assigned to men.

↳ *Productive Work.* Productive work relates to the economic activity that produces income. National economic agencies and accounting systems recognize these activities and consider them as input to national economy. This is considered as the men's arena.

The public/domestic dichotomy serves to maintain the division of production and reproduction functions in the economy. It is in the public sphere where productive value is acknowledged. Goods and services in this sector are fully recognized, remunerated and reflected in official statistics. However, outputs in the domestic arena are classified as purely of reproductive value, merely sustaining the requirements of the so-called productive sector.

In truth, women also engage in gainful employment to meet the basic needs of the family. Despite data which show that one-half of world's household is headed by women, their contribution is considered as supplementary to the primary breadwinner. If men, on the other hand, perform reproductive functions,



they do so temporarily and receive much appreciation from women.

Women who work outside the home are still responsible for the household chores even if these are at times passed on to other women, like housemaids, who take on surrogate housewife roles. This dual responsibility is what is commonly referred to as a woman's double burden. The double burden not only extends the daily working hours of women but invariably hampers the sharpening of their intellectual and creative potential as well as limits their own career options.

- ↳ *Community Work.* Community work relates to the participation in social, political, cultural, and other public activities. The division of labor is carried on in this arena. Thus, men engage in politics or other high profile and visible roles, while women perform organizing and support activities like clean and green projects, or spiritual and church-related endeavors.
- ↳ *Consequent Bias Against Women.* Since productive work is given more importance than reproductive ones, men are perceived to have a primacy in society because they perform most of the productive work. On the other hand, because of their biological make-up, women are assumed to be less capable in the productive arena and are relegated to the reproductive sphere and its extensions, thereby confining them to what are considered to be secondary pursuits.

Since the family is the unit of reproduction, it follows that women, as household caretakers, are

instrumental in ensuring the survival of economic production even as production itself is assumed to be the more important aspect of society. With women managing the homes, male workers are relieved of domestic tasks to take on income-earning activities. Men are, therefore, better able to fully participate in economic, political and cultural endeavors in which productive value is recognized. Their exposure in the public sector results in their being acknowledged as the dominant gender in all spheres of life.

Meanwhile, the women - both the housewives and those who shoulder the double burden - are perceived to have minimal social and economic contributions, even as they perform a broad range of activities in the home and even as they earn a living outside the home. In both instances, women are perceived as being merely supportive and, therefore, secondary or even marginal.

Because women's contributions have remained both largely invisible to the public eye as well as perceived to be merely secondary, women's active participation in public life has not been as extensive as that of men. This subordination also accounts for the lack of support systems and social benefits for women, the limited access and control that women have over resources, and the comparatively minor roles that women play in national development.

This prevailing system inevitably provides the context for the creation of any nation's laws. The essence of the production/ reproduction dichotomy has clearly permeated the nature of the legal system. Despite significant breakthroughs, Philippine laws, in general,

merely reflect the subordination of women in Philippine culture. For example, the Family Code reinforces male authority and dominance in the family. Decision-making in the exercise of parental authority, legal guardianship over the property of unemancipated children, and the administration and enjoyment of community and conjugal partnership properties are the husband's prerogatives.

- ↳ *Addressing the Issue.* The pursuit of equality and parallel development between the sexes is not and should not be motivated by anti-male sentiments and reverse sexual domination. Neither should an urgent concern for women be governed by a competitive stance. In the final analysis, the compelling reason for gender-responsive development is premised on the genuine realization of the Constitutional provision which envisions a society that recognizes women as equal citizens of the nation and as full partners in national development.
- ↳ *Summary.* Society assigns specific roles, behaviors and attitudes to men and women. The result is gender relations based on culturally-defined distinctions that have traditionally relegated women to secondary or discriminatory roles. This reality of unequal power relations between men and women must be addressed to attain a holistic social, economic, political, cultural development of people and society as a whole.

## **Materials Needed**

- White board markers or chalks
- White or blackboard

# ***Manifestations of Gender Bias***

---

## **Introduction**

This session is the second in the appreciation of basic gender concepts. The first session focused on how socially constructed norms on the roles and capabilities of women and men have resulted in discrimination against women. In the second session, the impact of gender bias will be discussed in more detail and concrete examples will be provided for each manifestation of gender discrimination.

## **Rationale**

The discussion of sex and gender paves the way for a deeper understanding of existing unequal relations between women and men in different societies. However, the conceptual discussion of the basic ideas of sex and gender should be related to more concrete experiences in the lives of men and women. A discussion of the different forms of gender bias found in the different institutions in our society will reinforce the fact that these biases have long been ingrained in our practices, customs, and consciousness. Overcoming these biases can only be achieved effectively through collective action, which starts through raising community awareness.

## **Objectives**

At the end of the session, the participants should be able to:

- ↳ identify the different manifestations of gender bias, and
- ↳ provide concrete examples of manifestations of every identified gender bias.

### **Core Messages**

1. Acts of gender bias are prevalent and can be categorized as economic marginalization, political subordination, multiple burden, stereotyping, violence against women and personal effects on women.
2. The biases are culturally rooted; however, they can be changed to effect a gender-sensitive and more egalitarian development.
3. Women and men are both stakeholders in the quest for people-oriented development.
4. Both women and men must work for gender equality as an end-goal of development.

### **Activity 5** : Identification of Manifestions of Gender Bias (30 Minutes)

**Methodology to be used:** Film Showing of "Impossible Dream"

#### **Instruction:**

1. Before this session, the trainer should preview the short film "Impossible Dream" and familiarize herself/ himself

with it. The trainer should be able to identify the roles, relationships and access to resources shown in the film as these are the points that the participants are expected to identify.

2. During the session, show the film "Impossible Dream". The film runs for about 15-20 minutes. After the film, the processing will depend on answers to the following questions:

↳ What are the roles/ activities, tasks of the women/ girls and the men/ boys in the film?

↳ Who has access to and control of resources and benefits?

3. Ask the participants to identify the roles played by the man/ woman/ son/ daughter in the film. Write down their answers on the board. The following are examples of the roles and activities that should come out:

<b>Woman/ Mother</b>	<b>Man/ Father</b>	<b>Daughter</b>	<b>Son</b>
<ul style="list-style-type: none"> <li>- Wakes up ahead of man</li> <li>- Prepares and serves breakfast</li> <li>- Does the laundry/ ironing</li> <li>- Takes care of baby</li> <li>- Takes the children to school</li> <li>- Leaves the baby to another person</li> <li>- Works at the factory</li> <li>- Goes to the market</li> <li>- Cooks dinner</li> <li>- Crochets while watching TV</li> </ul>	<ul style="list-style-type: none"> <li>- Served breakfast by woman</li> <li>- Works as a construction worker</li> <li>- Drinks beer after work</li> <li>- Watches TV after eating</li> </ul>	<ul style="list-style-type: none"> <li>- Helps the mother in housework</li> </ul>	<ul style="list-style-type: none"> <li>- Copies the acts of the father</li> </ul>

Other roles may be added to this list.

4. Then, ask the participants to identify who has access to resources as shown in the film. The following answers may be given:

- ↳ **Income.** While both man and woman work outside the home, the woman receives less pay than the man.
- ↳ **Food.** The woman is the last to get her share of food. And she even shares with the child.
- ↳ **Resources.** As shown in the film, the woman also helps in the farm but she has a double burden (carries the baby on her back), and uses more primitive farm tools than the man. Farm tools are designed more for the use of the male-farmer than the female-farmer.
- ↳ **Leisure.** The man chooses the form of entertainment to watch and when to have it. Notice that he turned off the T.V. while the woman was still watching.
- ↳ The son also has more privileges and access to resources than the daughter. One scene showed the woman knitting something for the son but not for the daughter. This suggests that even with children, sons may be favored over daughters.

This is not an exhaustive list. The trainer and participants can still identify others not mentioned here.

5. To make sure that as many role as shown in the film are identified, guide the participants by recalling the scenes shown in the film.



## Materials Needed

- VHS tape of "Impossible Dream"
- Television set
- VHS Player
- Manila paper or board (for processing of observations)

## Activity 6 : Synthesis and Clarification

**Methodology to be used:** Inputs and Lecture-Discussion

### Instructions:

1. Since the film in Activity 1 is a take-off for the discussion on manifestations of gender bias, the trainer summarizes the film by discussing the productive-reproductive roles, the sexual division of labor and the manifestations of gender bias, such as marginalization, subordination, multiple burden, violence against women, stereotyping and the effects on personhood.
2. As each manifestation is discussed, post the corresponding part of the "altar", which is actually the symbol for women (♀). [Note: The symbol has six (6) different parts corresponding to the six (6) different manifestations of gender bias.]
3. At the end of the session, the altar is complete and hopefully the image will be left in the minds of the participants.

## **Discussion Points:**

1. While Filipino women do not suffer from the more glaring forms of gender inequality practiced in other countries (e.g. the dowry system, genital mutilation, wife-burning, female infanticide, vaginal sewing), they nevertheless have to contend with a host of interrelated factors which produce and reinforce inequality. Such unequal and even oppressive relations are manifested in various interpenetrating levels. For heuristic purposes, six spheres of discrimination can be identified, as follows:

### **↳ Economic Marginalization**

- a. Under or non-valuation of women's work

The tasks that are related to housework, child-rearing and family care are largely taken for granted and perceived as minor functions that are once in a while given patronizing importance. However, these are generally seen as "natural" functions that have no direct contributions to societal development.

- b. Unequal pay for work of equal value

In the private sector, a Department of Labor and Employment (DOLE) study shows a disparity of more than a thousand pesos per month in the salaries of male and female workers. This gap increases significantly from unskilled to managerial and supervisory levels (DOLE-Institute of Labor Studies, 1991).

In the rural areas, agricultural and fisheries work are automatically considered to be male occupations even as women perform a host of functions in these endeavors.

Even in the government bureaucracy, where salary scales are pegged to positions and ranks, female-dominated professions start off at a lower scale. For example, the positions of Nurse 1, Teacher 1, and Pharmacist 1 are pegged at salary grade 10, level 2 while Sociologist 1, Zoologist 1, Aquaculturist 1, Economist 1, Planning Officer 1, to name a few, all start at salary grade 11, level 2.

c. Last to be hired, first to be fired

It has been the practice of private companies suffering from the adverse effects of globalization to resort to cutting down on operational costs, particularly, labor costs. Women are the first victims of this practice. Since they are perceived to be secondary income-earners to the men, they are the first to be retrenched.

Women's access to job opportunities, particularly, married women, is very limited due to the additional financial burden they bring to their employer who will be obliged to provide certain benefits to them such as maternity leave. Thus, they are given last priority in hiring.

d. Limited opportunities

Studies have shown that females tend to be given less access than males, to training opportunities

and concomitantly, to promotions. A DOLE-ILS study in 1991 found that male workers receive training more frequently, have more fringe benefits, and are promoted more often than female workers.

e. Exacting sexual favors

Exacting sexual favors in exchange of economic benefits, either to get hired, receive a promotion, retain one's job, or simply as an "occupational hazard", is a reality many women are forced to accept.

↳ Political Subordination

a. Higher regard for the status of men in society

Politics is an issue of power, at whichever arena a person participates in. Because the productive sphere is given pre-eminence in society, because women are viewed as the "weaker sex" and their capabilities - whether in the home or in the public sphere - are not recognized, because men are traditionally assumed to be the heads of households and organizations, women do not have the same power and prestige, status and societal position as men (NCRFW, 1995).

Whether in the home, the community, the workplace or society at large, women are generally expected to play supportive roles to men and to accept a subordinate status. Such a reality limits women's participation in decision-making and

assumption of leadership positions, thereby hindering their full development. Such subordination is manifested and expressed even in legal and extra-legal discrimination.

In the home, the authority structure is generally based on male dominance. Major decisions are the prerogatives of men. Commonly accepted descriptions of males, like "haligi ng tahanan" or head of household, bear witness to the ascendant role of the male sex in family life. Even the phrase "under de saya", negatively attached to a man, emphasizes the assumed subordination of women.

b. Higher positions of men in the family and organizations

In the community, a woman's status is also largely subordinate to men. Leadership in organizations and major decision-making bodies are primarily in the hands of men.

The same is true in the workplace. As of June 2002, women constituted 34.2 percent of the 115,889 total members of registered public sector unions. Women still are a minority in leadership positions: there were 65 women union presidents and 1,536 women union officers in the same year. In the private sector in 1993, 41.4 percent of union members were women, a decrease in percentage from 52.31 percent in 1990 even if the total number of female members increased by more than 86,000.

It is significant to note that in 1991, 58 percent of career service employees in government were women. However, in third-level positions in government, women only accounted for 30.3 percent. The majority of women in the career service, 68.5 percent, are found in second-level positions.

Although there is a perceptible trend towards greater participation of women both in elective and appointive positions, women are still very much in the minority. From 1946 to 1992, the highest percentage of women in the House of Representatives was 13.5 percent in 2001 and in the Senate, 25 percent in 1967. For the entire period 1946-1992, the average number of elected women was only about six percent. Among local elected officials, the ratios remain essentially the same. In the 1995 elections, the percentage of elected women officials ranged from a low of 6.2 percent for city mayors to a high of 17.10 percent for vice-governors.

c. Men's decisions are generally followed

Men are raised and trained to take an active role in decision-making and participation in public life. Their first training ground is the family. Thus, fathers make the major decisions concerning the family such as the place of abode and number and spacing of children.

- d. Women are trained/ socialized to be subordinate to men. Women, on the other hand, are brought up to accept the leadership role of men and to defer to men even in decisions involving the family and their personal life. Their socialization revolves around being subservient to either their father or husband. "Filipino girls are trained at a very young age to be responsible for the home and their younger siblings. As wives and mothers, they often subsume their own personal needs to the needs of the family (Eviota,1994)."

#### ↳ Gender Stereotyping

- a. The economic marginalization and political subordination of women are created and reinforced by a host of institutions and structures. These include the family, the educational system, workplace, media,—government programs, legal system and religions.
- b. Women are stereotyped from birth

Societal perceptions and value systems ingrain an image of women as weak, dependent, subordinate, indecisive, emotional, and submissive. Women's roles, functions, and abilities are seen to be primarily tied to the home. Training and work opportunities are extensions of reproductive functions. There are two very vivid pictures of women — the virgin and the vamp. These apparently contradictory models are interchangeably used: women are expected to be pure and chaste while at the same time treated as

sex objects. In a very real sense, women are trapped within these stereotypes which severely limit their opportunities for development, expose them to innumerable hurdles, and consign them to a fate that robs them of the right to be equal to men. (NCRFW, 1995)

Stereotyping is seen in the following areas:

- Child-rearing

The manner of socialization of children is dependent on their sex. Daughters are expected to help their mothers with household chores and stay at home, while sons are allowed to play with their war toys and cars outside the house.

- Religion

Most dominant religions continue to stereotype and discriminate against women. Religious hierarchy is still male-dominated. Very few religions allow women to serve as ministers or priests. In ancient Jewish tradition, women are forbidden to enter synagogues, the place of religious worship and instruction.

- Occupations

With the continuing perception that women are secondary income-earners, employment opportunities for them have been limited to work closely related to housework. They are often employed as community and social workers, and



workers in commercial and retail trade and manufacturing.

- Education

Although the proportions of girls and boys finishing elementary and secondary schools are almost equal, stereotyping in the educational system still exists, particularly, in the tertiary level. Trends in course preference in the tertiary level show that women tend to pursue courses related to their household work such as nursing, teaching and service trades programs. Men still dominate the engineering, transportation, and physical science fields.

Contents of textbooks reinforce the image of females as subservient mothers and well-behaved little girls, and of males as workers and adventurous little boys.

- Language

The English language contains gendered nouns and pronouns, i.e. man to refer to humankind and "he" to any abstract individual. While these terms are considered generic languages, the images they create pertain to men. This reinforces the notion of men as the primary social players and of women, as invisible members of society.

- Behavior

Women imbibe an entire view of culture and society. Their aspirations are bound by

motherhood functions, and dispositions and behaviors are moulded based on what society expects from them. They are expected to take on domestic responsibilities while men are expected to dominate the public arena. These expectations mold their behavior in the family and in the public sphere.

- Government Program

While the government has become more sensitive to the situation of women, much still has to be realized. Majority of government programs are still gender-blind. Women's concerns are still largely consigned to the social sector, as this has been perceived as the soft sector. Integration of women's concerns in the economic and infrastructure sectors is yet to be seen.

- Media

The print media, broadcast media and movies have portrayed negative and traditional images of women from subdued housewives, to emotionally dependent martyrs, to scheming bitches, to victims of rape and other violent acts. Advertising, on the other hand, uses women as sexy come-ons to get people, particularly men, to buy male-oriented products such as alcoholic drinks and cigarettes. (Eviota, 1994)

- Popular Culture

## ↳ Multiple Burden

Women, even as they are viewed as having primarily reproductive functions, actually participate in a host of other activities. Women are part of the labor force, not only because housework and child-care are productive activities, but also because women work in agriculture, fisheries, manufacturing, service occupations, the informal sector, industry, and the various professions. While women put in essentially the same working hours as men outside the home, housework and child-care are still primarily a woman's concern. As a result, women carry a double burden in terms of longer hours of work and a wider breadth of responsibility.

Apart from these, women also participate in socio-cultural and political activities in community affairs, church-related functions, civic activities, and political involvements. This produces a multiple burden because they almost single-handedly have to carry the burden of housework and child-care. The multiple burden necessarily limits every woman's capacity to develop herself while affording men the luxury of concentrating on concerns of their own in the public sphere.

## ↳ Violence against Women

The four manifestations of gender bias mentioned above provide the bases upon which violence against women occurs. Essentially, these are likewise violations of human rights.

Women are potential and actual victims of specific kinds of violence that are distinctly different because these acts are borne out of the status of women in society. There is a web of verbal, psychological and physical abuse that all women are exposed to. Because of their low status in society, many women experience a variety of verbal abuse: This, coupled with psychological assaults — insults, threats, emotional blackmail, especially in relation to children, economic dependence, etc. — violate a woman's dignity.

Aggravating the effects of verbal and psychological abuse is physical violence against women. Sexual harassment is a reality all women are potential victims of. From the childhood "games" of boys peeping at girls to various acts of lasciviousness, from seduction to abduction, from molestation to wife-beating, from prostitution to rape — all these are crimes that specifically apply only to women, with very few exceptions. Special mention must also be made on the corruption of minors and the abuse of children that have a direct effect on women because they, after all, feel a deeper sense of responsibility for the young.

The following are some of the different forms of violence against women:

- Rape
- Sexual Harassment
- Domestic Violence
- Prostitution
- Trafficking in Women

## ↳ Effects on Personhood

All the above-mentioned manifestations of gender bias have a direct negative effect on the personhood of every woman. Growing up and living in a world which limits a woman's very right to be human, which operates on a double standard that applies to the sexes, which diminishes an individual's dignity, hits the very core of each woman's personhood. As a result, females generally possess lower levels of self-esteem and confidence compared to males.

Coupled with the obstacles that women have to confront in developing a sense of self-worth is the reality that gender discrimination does not only occur in arenas external to women—the workplace, the community, social institutions like the family, media, etc.—but also with regard to their own bodies.

In the context of women's subordination within the family, for instance, sexuality is often repressed because traditional perceptions dictate a submissive role for women. In fact, in the entire process of socialization, sexuality is rarely viewed as an issue that women should be concerned about. In terms of women's health, services are largely limited to maternal concerns with little emphasis on other ailments like urinary tract infections, psychological health and sexually-transmitted diseases. Even in the issue of reproductive health and family planning, information and services still can be improved and the participation of women in deciding on population policies still needs to be enhanced.

2. These manifestations of gender bias are further aggravated by national realities. The disparity in wealth and power, elite democracy, economic policies and development priorities, all contribute to the further marginalization of women and the feminization of poverty. In the international arena, women reel from structural adjustment programs, the international division of labor, and the manner in which the international economic order is structured.
3. These manifestations are culturally rooted. Norms and values are handed down from generation to generation and manifest not just in people's behavior and way of relating to family and friends, but also in societal structures, institutions and laws. Hence, addressing gender biases must also be multi-disciplinary. Responses should include, among others, re-education, capability-building, direct social services, and law and policy reform. The last part is one of the main concerns in the training.
4. Laws can be a powerful tool in achieving the changes that gender advocates espouse. Policies, programs, structures, and allocation of budgets are important aspects which must be addressed when re-defining norms and values to make them more gender-responsive. Thus, in responding to the prevalence of domestic violence, local government units may need to enact ordinances that would build the capacity of the barangays in addressing the issue so that when a survivor seeks the help of barangay officials, they are able to provide the necessary assistance.
5. As local legislators and policy-makers, the participants are in the best position to start re-defining the lives of

women— and men—in their communities. By enacting gender-responsive local legislation and policy issuances, the participants will be catalysts of change for a more humane and egalitarian society

*(Primary source: David, Karina C., Gender Seminar for Men: The Hasik Experience, 1995)*

### Materials Needed

- Transparencies of key points in every MGB
- MGB "altar": (see next page)

Marginalization

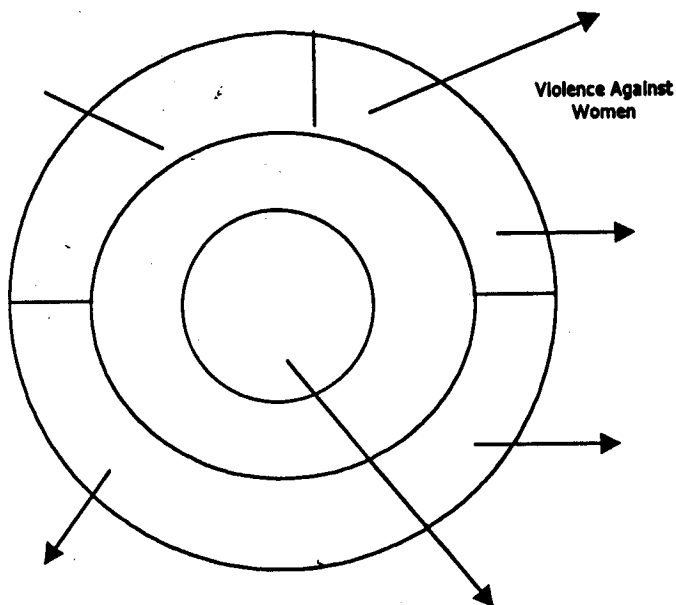

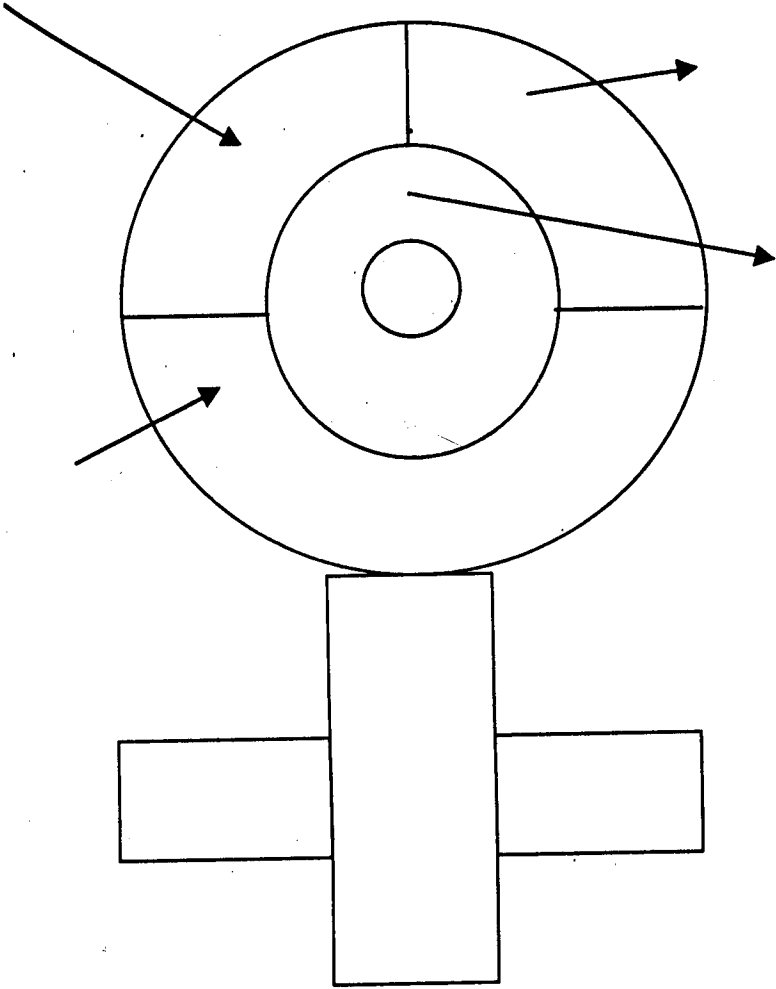



# ***Personal Reflections***

---

## **Introduction**

This session is intended to give the participants an opportunity to examine the different forms of gender bias as reflected in their personal lives. The participants shall take a look at their personal lives to identify concrete examples of gender bias and other gender-related issues discussed in the previous sessions.

## **Rationale**

To be a gender advocate, concepts in gender equality should not be left to the cognitive level of appreciation. There is a greater chance of transforming the participants into gender advocates if and when they feel moved by the cause. Hence, the training should not only be cognitive but also affective. This session allows the participants to look at their own personal experiences and see which of the basic gender concepts discussed in the prior sessions have had an impact in their lives.

## **Objective**

At the end of the session, the participants should be able to reflect on their personal experiences of gender discrimination.

## Core Messages

1. All of us experience, in one way or another, different forms of gender-discrimination/bias.
2. Experiences of gender bias differ from person to person.
3. Gender bias, in whatever form it takes, affects one's development as a person.

## Activity 7

Reflection on Personal Experience of Gender Discrimination (1 hour)

**Methodology to be used:** Individual reflection session

### Instructions:

Instruct the participants to find a comfortable place inside the training compound where they can reflect about what they have discovered from the sessions on basic gender concepts vis-a-vis their personal history of gender discrimination. It may be necessary to write down some of these experiences to guide the participants in the next activity, which is the sharing within dyads.

2. Remind the participants to at least try to answer the questions formulated in the Discussion Points below. These questions serve as points for reflection. Stress the importance of being open and honest.

3. Direct the participants to return to the main session hall after an hour.

### **Discussion Points:**

1. Have you ever experienced any form of gender bias? Or have you been in one way or another perpetuating gender bias?
2. What were the circumstances surrounding such experience(s)?
3. How did you react to each experience of gender bias?
4. What steps/ actions did you take to prevent or stop the bias?
5. What were the lessons learned from those experiences?

### **Materials Needed:**

- Pens and pieces of paper

## **Activity 8**

Sharing and Presentation of Outputs at the Plenary Session (1 hour)

**Methodology to be used:** Group sharing and oral presentation

## Instructions:

1. After an hour of reflection, gather the participants in plenary. Instruct them to group themselves in pairs, following the partner-arrangement observed in the "*Bangka at Sagwan*" activity during the introduction. The participants should now proceed to share and discuss with their partners the results of their personal reflections, again observing the questions raised in the Discussion Points section above.
2. Tell the participants that if they are not ready to share the experience with another person, then they need not share the details of the experience.
3. After 45 minutes of sharing in the dyads, call the participants into the session hall.
  - ↳ Check how the participants felt about the session by asking two or three of them if they felt good (or bad or uncomfortable) about the session (either with the reflection or the sharing). Note that there is no need for the participants to recount their reflections.
  - ↳ Tell them that the purpose of the reflection is to make the issue of gender bias as close to them as possible. This way, the issue becomes more felt and is not left at the cognitive level.
  - ↳ Remind the participants that what they heard from their partners in the dyads is confidential as these may be very personal and may be painful or embarrassing experiences.

- ↳ Thank the participants for their openness and generosity.
- ↳ Lastly, remind them that reflections should be a continuing process. Even if they are painful, these experiences should allow us to learn and grow and become better persons.

# ***Conceptual Framework***

---

## **Introduction**

After having gone through sessions on "Sex and Gender" and "Manifestations of Gender Bias", the participants should by now agree that there is such a problem as gender bias. They should now be knowledgeable about the problems and issues that women (and men) face as a consequence of this gender bias. Responding to these issues is a challenging task for advocates. From the previous sessions, it was emphasized that much of the problem of gender bias is deeply rooted in a society's cultural values; thus, effective solutions to the problems entail multi-disciplinary approaches.

Local government units are not isolated from the problem. In fact, as can be deduced from the previous sessions, institutions such as LGUs may either perpetuate or address the problem of gender bias. On the one hand, there are LGUs that are indifferent to the problem. Despite numerous manifestations of gender bias, many local officials may not be sensitive to gender issues or may feel helpless or incapable of addressing them.

On the other hand, there are also LGUs that have a higher level of awareness. These LGUs have passed gender-responsive ordinances and integrated a GAD component in their annual budget. With the cooperation of vigilant groups in the communities, initiatives designed to address specific gender issues have been implemented.

Some of these initiatives have been successful and are being replicated by other LGUs.

## **Rationale**

In the task of integrating gender and development in local laws and policies, it is important to work within a framework that would guide the local legislators and officials in the analysis, implementation and evaluation of measures that have an impact on women's status and on gender relations. Different LGUs may face different gender issues, but the framework should be able to help them address these various issues more effectively.

## **Objectives**

At the end of the session, the participants should be able to:

- ↳ Appreciate the concept of gender equality as a human rights issue, different development approaches and gender equality and women's empowerment framework (GEWEF), and
- ↳ Understand the conceptual framework of integrating gender and development in local legislation and policy formulation, including the local government unit bureaucracy.

## Core Messages :

1. The principle of gender equality has been recognized internationally as an issue of human rights.
2. A just and sustainable society should ensure that the processes for policy-making promote gender equality and empowerment.
3. Local legislation and policy formulation are venues for ensuring gender equality and empowerment.
4. The processes involved in legislation and policy-making should be responsive to the promotion of gender equality and empowerment.

### Activity 9

Development Approaches (20 minutes)

**Methodology to be used:** Lecture-discussion

### Instructions:

1. Throughout the lecture, ask the participants evocative questions in order to facilitate a more active discussion. Some of the questions that may be asked are the following:
  - ↳ As far as you know, how does the WID approach understand the problem of women? What about WAD? What about GAD?



- ↳ What are the corresponding solutions of the WID approach? The WAD approach? The GAD approach?
2. Discuss the points stated above, and use visual aids in the presentation of the important points.

## **Discussion Points:**

1. Evolution of gender equality as a human rights issue
  - ↳ Gender equality has not always been recognized as a right, much less one of the basic human rights.
  - ↳ The UN Declaration of Human Rights, adopted in 1950, states that everyone is entitled to all the rights and freedoms without distinction as to race, color, **sex**, language, religion, political affiliation or other opinion. Yet, despite this provision in the Declaration, gender equality was not given any serious thought by governments and human rights advocates.
  - ↳ In the 1970s the feminist movement had become very strong and was able to push the UN to proclaim 1975 as International Women's Year. In the same year, gender equality went into the forefront of international discussion at the First UN Conference on Women.
  - ↳ The first conference was followed by three other world conferences. In these conferences, strategies towards the attainment of the equality of women and men were discussed and put in the agenda. In the Fourth World Conference in Beijing in 1995, a Platform for Action was formulated.

- ↳ It is this platform that contains the agenda for women's empowerment.
2. There are at least three (3) development approaches on gender that had evolved through the years.
- ↳ Women in Development (WID) emerged out of the First UN Conference for Women from 1975-1985. While this approach has changed over the years, and varies from country to country, there are common factors in the different WID frameworks, namely:
    - a. They focus on women as an analytical and operational category. This means that emphasis is placed on the professional practice of women in government and non-government organizations;
    - b. Its solution to the problem is a "technology fix", i.e. emphasizing transfer of technology, provision of services and credit facilities;
    - c. This has also brought about the establishment of separate structures for women's concerns, such as a Ministry of Women's Affairs (or in the Philippines, the National Commission on the Role of Filipino Women), and women's desks in various government agencies;
    - d. The separate structures are given a separate mandate, as if women were not involved in or affected by the activities of other Departments or Ministries;
    - e. The primary means of intervention of these separate structures has been women-specific policies, programs or projects, and

- f. These structures, whatever their form, suffer from severe lack of resources (financial and logistical etc).
- ↳ The second approach is Women and Development or WAD.
- a. This is a neo-Marxist feminist approach which was popular during the mid-70's.
  - b. It is premised on the argument that women's productive and reproductive work are central in the maintenance of society.
  - c. The focus of the approach is the relationship between women and the development processes, i.e., the women's condition within structures of international and class inequalities. It admits that non-elite men in the Third World, just like women therein, are also adversely affected by these structures of inequalities in the international system.
- ↳ The third approach is Gender and Development or GAD. Like the other approaches, GAD has varied frameworks and characteristics, depending on the country or organization where it is carried out. However, there are common characteristics to the GAD approach, such as:
- a. Focus is placed on gender relations. This means that the analysis comes from an understanding of women's roles, responsibilities, and access to and control over resources vis-a-vis the men's.

- b. It recognizes the subordination of women and considers the implications of power in gender relations when making an analysis;
- c. The response it espouses is a combination of separate structures and capability-building for the staff of existing structures;
- d. It puts emphasis on the participation of the State in promoting women's emancipation;
- e. The mandate for separate GAD structures aims to make the approach as a catalyst for the integration of the gender perspective in all development activities;
- f. The decision on whether to adopt women-specific interventions or integration into mainstream interventions, is a matter of strategic choice. Thus, in some contexts, women or men-specific interventions may be appropriate, while in other situations, gender integration into mainstream sector-specific interventions may be appropriate. Compared to the other two approaches, GAD welcomes more the potential contribution of men;
- g. The focus is also on the process and not only on ensuring more participation of women in the benefits of development, and
- h. GAD initiatives, like those of WID, are also under-resourced.

### **Materials Needed:**

- Acetate on the Matrix of Development Approaches

## **Activity 10**

Gender Mainstreaming Framework  
(30 minutes)

**Methodology to be used:** Lecture-Discussion

### **Instruction:**

The main activity is active lecture. Elicit participation by asking for illustrations or examples of communities or projects that have attained each level of empowerment.

### **Discussion Points:**

1. **Gender mainstreaming** is the (re)organization, improvement, development and evaluation of policy processes, so that a gender equality perspective is incorporated in all policies at all levels and at all states, by the actors normally involved in policy-making.
2. Gender mainstreaming as a strategy gained further recognition at the Fourth World Conference in Beijing, as other development approaches have been criticized as having resulted in marginalizing women even further.
3. One of the frameworks used in GAD mainstreaming is the Gender Equality and Women's Empowerment Framework (GEWEF),
4. GEWEF as a GAD Framework
  - ↳ The objectives of GEWEF are:

- a. to eradicate the prevailing subordination of women, and
  - b. to ensure gender equality (i.e. the equality of women and men); and women's empowerment (i.e., a process whereby women become capable of uplifting their status and condition).
- ↳ To be able to attain gender equality and women's empowerment, there are different levels that women may have to go through. These levels are:
- a. Welfare
    - material needs linked with with reproductive roles such as milk-feeding, vaccination, and other basic concerns such as food supply, income and medical care
  - b. Access
    - arises from women's lesser access to resources and the factors of production, e.g., land, labor, credit, services, technology, training, marketing facilities and all publicly available services and benefits,
    - equality of access according to the principle of equal opportunity. and
    - focuses on creating income-generating livelihood and opening more economic opportunities for women.

c. Conscientization

- Empowerment is recognizing that women's subordination is imposed by a system of discrimination that is socially constructed;
- Ability to critically analyze society;
- Myth: Women's low status and the traditional gender division of labor is part of the natural order or is God-given, and
- Focuses on transforming perspectives and consciousness, leading to the recognition that discrimination and economic or political domination of one sex by the other should be changed

d. Participation

- Gender gap most visible, easily quantifiable;
- Women, equally with men, are actively involved in the development process, and
- Focuses on women's equal participation in decision-making process; -- policy-making, planning and implementation, i.e., women in government and politics

d. Control

- Goal is to achieve equality of control over the factors of production and distribution of benefits; a balance of power, neither women nor men are put in a position of dominance; and
- Increased participation: increased development and empowerment of women.

## Materials Needed :

- Acetate showing the Levels of Empowerment Under GEWEF

### **Activity 11**

Conceptual Framework in Integrating GAD in Local Legislation and Policy Formulation (40 minutes)

**Methodology to be used:** Lecture-Discussion

### **Instructions:**

#### 1. Workshop:

- ↳ Divide the participants into groups of five (5).
- ↳ Give each group strips of cartolina where the following words/ phrases are found:
  - a. Women's participation
  - b. Women's representation
  - c. Livelihood projects for women
  - d. Woman mayor (or governor, depending on the LGU participating in the training)
  - e. Gender mainstreaming
  - f. GAD budget
  - g. Gender sensitivity training
  - h. National "gender equality" laws
  - i. International human rights documents
  - j. Gender awareness



- ↳ Each group shall have the same set of cartolina.
- ↳ Tell the groups that within 10 minutes, they should choose three (3) strips which they think should be components of integration of gender in local legislation and policy formulation.
- ↳ After 10 minutes, call all the groups to report at the plenary. Allow each group three minutes to explain their answers. *Note that there are no right or wrong answers. The main objective of the exercise is to allow the participants to ponder on the above concepts and connect them to the gender and local legislation/ policy-formulation.*
- ↳ Post all the groups' answers on a manila paper.

## 2. Active lecture-discussion

- ↳ When conducting the lecture, refer to the strips of cartolina that the participants had posted on the manila paper as concepts important to the topic.

## **Discussion Points:**

1. The State has a very big role to play in the attainment of gender equality and women's empowerment. Indeed, governments, including that of the Philippines, have shown that they can effect meaningful changes that would ensure women's full development. In the Philippines, the Constitution states that the State recognizes the role of women in nation-building, and shall ensure the fundamental equality before the law of

women and men (*Section 14, Article II, 1987 Constitution*). Local governments are not exempted from this mandate.

2. More often than not, emphasis has been given to the passage of legislation geared towards the promotion of equality before the law of women and men. One of these is Republic Act 7192 or "The Women in Development and Nation-Building Act". This Act affirms the view that women and men should enjoy the same status and conditions for realizing their human rights and potential to contribute to national, political, economic, social and cultural development, and to benefit from its results.
3. Even with the noble ideals stated in the Constitution and in RA 7192 and other laws, however, inequalities still remain both in terms of women's participation, and in the integration of women's issues and concerns in project development. A critical area that needs to be addressed concerns the content and process of policy formulation and legislation. Furthermore, although "gender equality" legislation may already exist at the national level, enabling mechanisms or appropriate executive and/or legislative issuances are still lacking at the local level.
4. Some Premises on Legislation and Policy Formulation:
  - ↳ The legislative process does not preclude economic, social and cultural agenda. In fact, legislation and policy must encompass all the economic, social and cultural problems women and men face. These problems are often in dire need of political and legislative action.

- ↳ The formulation of legislations and policies, their enactment, and their enforcement do not solely rest on government or its functions. The process includes government and non-government functions and functionaries. Women and men both inside and outside of government are "key" actors and stakeholders in the process.
  - ↳ However, to ensure a gender-sensitive legislative and policy-making process, gender has to be mainstreamed into the structures and organizations of government concerns, i.e., local government units and their respective departments.
5. Integrating gender in local legislation and policy-making means ensuring that legislation and policies crafted and passed contribute towards redressing the existing inequalities between men and women in all aspects. It may mean adopting uniform laws for women and men. But it can also mean otherwise, such as when there are real differences in the status and condition of women and men that allow for legitimate categorization and the provision of certain benefits or rights to one group. It further means that local legislators and executive officers are fully aware of the women's situation in their jurisdiction and are taking this situation into consideration when they assess the impact of their proposed ordinance or policy. It also means that local government units recognize that women are partners in development and should be given every opportunity for maximum participation in the crafting of laws and executive issuances. Women's perspectives and views cannot be fully articulated by representatives other than

women themselves; hence, women must be active participants in the whole process.

6. Towards this end, the DILG, together with the NCRFW and through the assistance of CIDA, has designed this training program to equip the members of the barangay, city, provincial legislative councils, as well as their counterparts in the executive branches in the mentioned LGUs, with the necessary analytical tools and skills. The training shall proceed as follows:

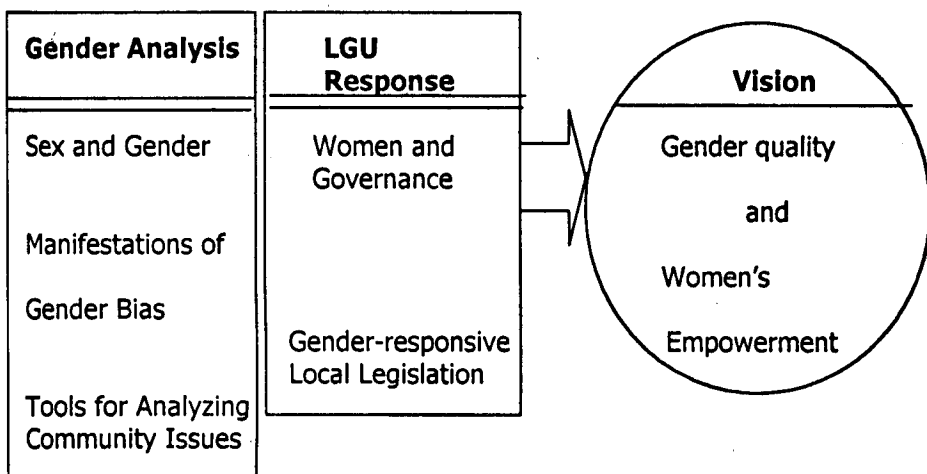

### **Materials Needed:**

- Several sets of cartolina strips on which the following are written:
  - Women's participation
  - Women's representation

- Livelihood projects for women
- Woman mayor (or governor, depending on the LGU participating in the training)
- Gender mainstreaming
- GAD budget
- Gender sensitivity training
- National "gender equality" laws
- International human rights documents .
- Gender awareness

- Acetate containing the framework

### Acetate 3: Flow of the Training

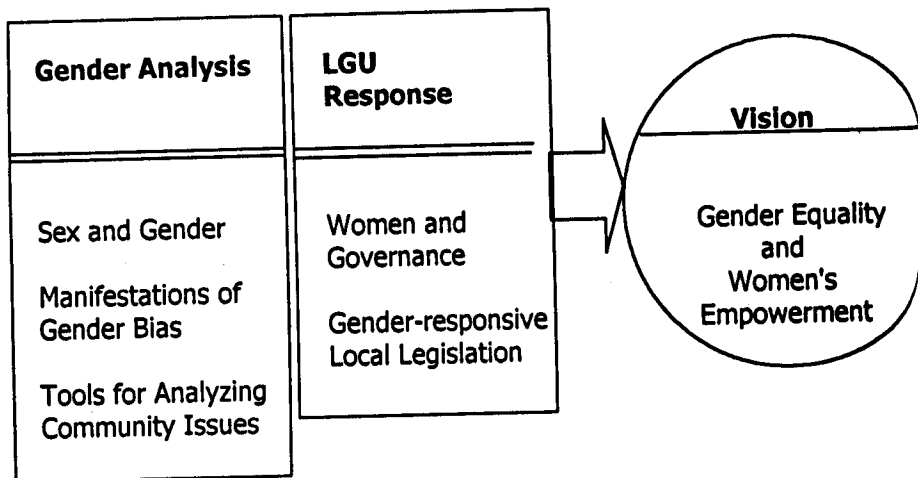

Matrix on Development Approaches

Acetate 4:

	WID	WAD	GAD
Analysis	<ul style="list-style-type: none"> <li>- Women's lack of participation in development</li> <li>- Women's lack of capability and experience to compete equally with men</li> </ul>	<ul style="list-style-type: none"> <li>- Women's oppression brought about by unequal relations between countries and classes</li> </ul>	<ul style="list-style-type: none"> <li>- Gender inequality</li> <li>- Unequal power relations between women and men that constrain women's participation in development</li> <li>- Lack of recognition by policymakers of the extent to which women are engaged in development but on an unpaid and undocumented basis</li> </ul>
Response	<ul style="list-style-type: none"> <li>- Developing new activities for women to increase their role in development</li> <li>- Training and capacity-building to enable women to compete equally with men</li> <li>- Special projects for women, usually in the area of livelihood</li> </ul>	<ul style="list-style-type: none"> <li>- Group women together on the bases of class, race or ethnicity</li> </ul>	<ul style="list-style-type: none"> <li>- The use of gender statistics: sex-disaggregated data showing the differences between women and men, and data on specific gender issues such as counting and valuing unpaid work</li> <li>- Gender training to raise awareness of gender issues and the extent to which they affect policies and programs</li> <li>- The use of gender analysis to identify differential impacts on women and men and to develop measures to address such difference.</li> </ul>
Critique	<ul style="list-style-type: none"> <li>- Focus is too much on the productive aspect of women's work, overlooks reproductive side of women's work</li> <li>- Accepts existing social structures (non-confrontational); does not examine the roots of women's oppression</li> </ul>	<ul style="list-style-type: none"> <li>- Fails to analyze the relationship between patriarchy and women's subordination</li> <li>- Gives little attention to gender relations of gender within classes</li> <li>- Like WID, it also fails to focus on the reproductive side of women's work</li> </ul>	<ul style="list-style-type: none"> <li>-</li> </ul>

**Acetate 5:**

**Levels of Empowerment Under GEWEF**

<b>LEVEL OF EMPOWERMENT</b>	<b>DESCRIPTION</b>	<b>ACTION FOR EMPOWERMENT</b>	<b>EMPOWERMENT ISSUES</b>
Control	Ultimate level of equality and empowerment	Equal representation, active roles in development, recognition of contributions, Maintaining and seeking higher goal	How can we sustain and aim high?
Participation	Women have moved to a level where they take decisions alongside men	Organizing themselves, working collectively, they gain increased recognition	With what means?
Conscientization	Recognition that problems stem from structural institutional discrimination	Recognition of their role in reinforcing or changing their disadvantaged situation	What can we do about them?
Access	Involves equality in access to resource	Recognition that lack of access is a barrier to growth and well-being	Why do we have problems?
Welfare	Addresses only basic needs without attempting to solve underlying structural causes	Empowerment involves the desire to understand own problems and needs	What are our problems?

# ***Women and Governance***

---

## **Introduction**

After the presentation of the conceptual framework, the participants shall now be introduced to the topic of (local) governance and gender advocacy. By now, the participants should be well-versed with gender concepts and should be convinced that gender equality and women's empowerment are ideals that local governments must aspire for.

## **Rationale**

This session will introduce the area of governance and the opportunities therein for gender advocacy. By way of introduction, it shall first delve on concepts in governance that will be necessary in understanding the power of local legislation. Principles that encourage the integration of GAD in local governance will also be discussed. Finally, the venues for women's participation will be identified in order to point out that local legislation, among others, is a potent venue for the integration of GAD in local governance.

## **Objectives**

At the end of the session, the participants should be able to:



- ↳ understand the basic structures and powers of the national and local governments;
- ↳ identify the venues for women's participation in local governance, and
- ↳ identify structures and principles that will encourage or enhance gender integration in local governance.

## **Core Messages**

1. Knowledge of the national government's powers, structures and mechanisms is necessary to understand how the exercise of governmental powers and functions can address gender concerns.
2. Given the local governments' special role and broadened powers under a decentralized system of governance, the different governmental structures and decision-making processes within the local government unit are important targets of advocacy efforts for GAD.
3. As local government officials, the participants are in a position to effect changes towards gender equality through gender-responsive local legislation and policy formulation.

### **Activity 12**

National and Local Government ( 15 minutes)

**Methodology to be used:** Lecture Discussion

## **Instructions:**

1. Discuss the topic as outlined below .
2. As part of Activity # 3 and before the lecture on venues for women's participation in local governance, divide the participants into three (3) groups.
3. Give each group a situational problem, written on manila paper or acetate. The situational problems are:

### ↳ Situation # 1

Kalinaw City is relatively prosperous. Under the leadership of the incumbent Mayor, Hon. Joe Jose, the City was able to get enough resources for various projects. The City Council is an enthusiastic group of people but with very conservative perspective.

Despite its progress and prosperity, Kalinaw City is not devoid of problems. There has been an increase in the reported incidence of rape and wife battery cases.

"KABABAIHAN," a group of women leaders in an urban poor community in Kalinaw, has been conducting activities to raise the awareness of community members on the issue of violence against women. It now wants to raise its advocacy to the City level.

- a) How can KABABAIHAN engage the City Government to act on VAW?
- b) As the Mayor, how will Mayor Jose respond to the problem of VAW? How will the City Council react to the situation?

↳ Situation # 2

The Municipality of Kapayapaan is rich in natural resources. Its forests are still relatively well-preserved and its rivers are still clean. Life in Kapayapaan is relatively peaceful.

The Province of Kawayan, of which Kapayapaan is a component municipality, however, has a different perspective in terms of development. It equates development with technological advancement and commercialization. Thus, it agreed to open a seaport in the province for the use of American military forces, as provided for in the Visiting Forces Agreement (VFA). This port will be located in Kawayan.

A Mothers' Club group in Kawayan opposed this development. They foresee the proliferation of entertainment establishments that would cater to the needs of the American soldiers. Specifically, they anticipate the growth of prostitution and other related activities that would endanger the lives of the people, and the women in particular.

- a) What can the women do in order to stop the plan of the Kawayan provincial government?
- b) What can the Kapayapaan local government do?

### Situation # 3

When he took his position as Mayor of San Vicente, Mayor Sanchez was seen as a catalyst of change and progress. However, the people of San Vicente later found out that Mayor Sanchez is abusive in his relations with the people that he is supposed to serve.

A group of female Municipal Hall employees complain that Mayor Sanchez sexually harasses them. A woman of the nearby town filed a case of rape against the Mayor, but lost because the Presiding Judge was biased in favor of the Mayor.

A group of women advocates in San Vicente want the Mayor to be penalized for his abusive behavior towards women. Some even want him to be removed from office.

- a) What can the women of San Vicente do?
4. Ask the groups to read the situational problem assigned to them, discuss the answers to the questions and role-play the situation, together with the answers to the problem questions. Give the groups 15 minutes to analyze the problem and 5 minutes each to act out the results of their discussions.

5. After the presentation of the groups, ask the participants what courses of action were presented by each group. This should not take more than 5 minutes. Note that one situational problem may call for several courses of action.
6. Write down the courses of action on the board, and refer to them while giving the lecture on venues for people's participation.

## **Discussion Points**

### **1. National Government**

- ↳ A State is quite often compared to a ship at sea. It is the government that sets the direction for the State and, at the same time, is responsible for maintaining order within.
- ↳ In the Philippines, the government's power over society is derived from the grant of authority that has been given to it by the people in the exercise of their sovereignty. Sovereignty is defined as "the source of ultimate legal authority." This is further expressed in the Constitution which states that, "the Philippines is a democratic and republican state. Sovereignty resides in the people and all government authority emanates from them." Hence, while the government wields a wide scope of power, this power is derived from the people.
- ↳ States possess three inherent powers: police power, eminent domain and taxation. Principally, it is through

the government that these powers are exercised by the State and are considered inherent.

a) Police Power:

- The most essential, insistent and the least limitable of powers, extending to all the great public needs.
- Enables the government to prohibit all that is hurtful to the comfort, safety, and welfare of society."

b) Taxation

- Because a government cannot function without resources, it has the power to raise revenue, including taxation.
- The power must be exercised for a public purpose, and it must be uniform, equitable and progressive.
- Just like the other powers, the exercise of the taxing power depends primarily on a legislative determination of what to tax and how much to tax it.

c) Eminent Domain

- The ultimate right of the sovereign power to appropriate, not only the public but private

property of all citizens within the territorial sovereignty, for public purposes.

- The expropriation must be for some public use or purpose.

↳ The Philippine government functions by way of three departments: the legislative, executive and judicial.

#### a) Legislative Department

- The principal actor in the exercise of the three great powers is the legislature, or the law-making body. In theory, the legislature must first set the entire process into motion before the other two departments can act on a matter. It is therefore logical that the discussion begin with the legislature.

#### b) Executive Department

- While it is Congress that makes laws, it is the executive that has the responsibility to administer and implement these laws.

#### c) Judicial Department

- Per *Sec. 1, Art. VIII, 1987 Constitution*, judicial power is "vested in one Supreme Court and in such other lower courts as may be established by law."
- Its primary function is to interpret the law in the course of settling disputes. One of its

other main functions is "judicial review," i.e., the power to determine whether a government official or agency has acted with grave abuse of discretion.

## 2. Local Government

- ↳ Local government units, like the national government, also have police power, power of eminent domain and the power to tax.
- ↳ Local government units also have a legislative department and an executive department. However, they do not have a judicial department.

### a) Executive Department

- Headed by the barangay captain, city/ municipal mayor, and provincial governor

### b) Legislative Department

- Composed of the barangay/ city/ municipal councils and the provincial board
- Unlike in the national government, there is a blurring of the lines between the executive and legislative branches because in local governments, the legislative department is headed by the following:

Barangay: Barangay captain  
City/ Municipality: Vice-Mayor  
Province: Vice-Governor



### c) Judicial Department

- There is no judiciary in the local governments. What is somewhat akin to the judicial department is the "*Katarungang Pambarangay*" where actual controversies and disputes are brought for conciliation. However, there is no decision by a judge in this local government mechanism.

## **Activity 13**

Some Principles that Encourage or Enhance Integration of Gender in Local Governance (15 Minutes)

**Methodology to be used:** Lecture-Discussion

### **Discussion Points:**

1. Women's rights are human rights. Governments are mandated to protect and promote these rights.
2. Women comprise half of the world's human resources.
3. Governments are mandated to fully promote human development.
4. All issues are women's issues. All community issues must be analyzed on how they impact on women.
5. Women's participation in local legislation and policy formulation will enhance the end product, empower the

women, and promote the full development of the community.

6. Gender issues have different dimensions. Thus, in addressing gender issues, governments should not be limited to local legislation and policy formulation.

## **Activity 14**

Venues for Gender Advocacy within the LGU (1 hour)

**Methodology to be used :** Workshop and Lecture-Discussion

### **Discussion Points:**

1. Membership in the local legislative bodies
  - ↪ Women have as much right as men to run for local government position. They can run for the executive branch as well as the legislative branch.
  - ↪ Under the Constitution and the Local Government Code, the legislative bodies shall have sectoral representatives. The women's sector is one of the three sectors represented in the local legislative bodies.
  - ↪ As Council or Board members, women can advocate for local ordinances that will address gender issues in the community.

↳ It may be strategic for women council or board members to chair the legislative committees on women and family relations, so that they have a stronger voice in the crafting of women-related ordinances.

## 2. Legislative lobbying

↳ Even as ordinary citizens, women can lobby for the passage of ordinances. As constituents of the local officials, they have the right to be heard on their positions on proposed legislative measures. They may also draft proposed ordinances and ask members of the council to support the same.

## 3. Positions in the Executive Department

↳ Women can also run for the position of barangay captain, mayor or governor. If they win, they will have the authority to implement local ordinances and to formulate policies in the implementation thereof.

## 4. Initiative and referendum

↳ The power of initiative confers on registered voters the right to directly propose an ordinance to the local council. Referendum, on the other hand, is the legal process whereby registered voters may approve or disapprove a resolution or an ordinance already passed by the local legislative body.

## 5. Mandatory prior consultation

↳ This refers to the consultation that is required to be conducted by national agencies or offices with the LGU, non-governmental organizations, and peoples' organizations and other affected sectors before a project is implemented in the LGU.

## 6. Local special bodies

↳ Under the Local Government Code, NGOs and POs may have representatives in the local special bodies. These bodies are the:

- a) Local Development Council (LDC)
- b) Local Pre-qualification, Bids, and Awards Committee (PBAC)
- c) Local School Board
- d) Local Health Board
- e) Local Peace and Order Council
- f) People's Law Enforcement Board (PLEB)

## 7. PO/ NGO-LGU Partnership

↳ Under the LGC, POs and NGOs may enter into partnerships or joint ventures with LGUs for the purpose of working together in the delivery of basic services, capability-building and livelihood projects.

## 8. Recall

- This refers to a process whereby registered voters may remove from office an elected local official before his or her term ends.

## 9. Disciplinary Action

- Registered voters may ask for the imposition of disciplinary action on erring local elected officials. The penalties that may be imposed range from suspension to removal from office.

### **Materials Needed**

- Manila paper or acetate on which the situational problems are written.
- White/ black board and markers/ chalk

# ***Legal Mandates for Gender and Development***

---

## **Introduction**

After discussing the moral imperative to integrate gender in local legislation and local policies, it should be pointed out that there is likewise a legal mandate to do so. There are laws and other legal instruments that require the inclusion of women's agenda and the active participation of women in the decision-making processes, such as in the formulation and implementation of local legislation. Thus, women in governance is not just a general demand for a fuller participation of women, but also a legal obligation.

## **Rationale**

As already mentioned, the local government unit's obligation to protect and advance gender equality has a strong legal basis. In fact, over the past decades, more and more international instruments and national laws call for governments and civil society to pro-actively respond to inequalities brought about by gender relations. These laws and instruments need to be discussed as they lay down the responsibility of the government. For the LGUs, these documents may also serve as guiding posts for policy direction in the area of gender and development.

## **Objectives**

At the end of the of the session, the participants should be able to:

- ↳ Define the Philippine government's commitments to the international community to respond to gender issues;
- ↳ Enumerate the important constitutional provisions, local laws, and the Philippine Plan for Gender-Responsive Development (PPGD) which are intended to address gender inequality, and
- ↳ Distinguish their critical role in addressing gender inequality through gender-responsive local legislation and policy formulation.

## **Core Messages**

1. The national and local governments are legally bound to respond to gender inequality through laws, policies and programs
2. As local government officials, the participants are in a position to effect changes towards gender equality through gender-responsive local legislation and policy formulation.
3. LGUs are powerful mechanisms for successful endeavors in GAD mainstreaming

## **Activity 15**

Leveling-Off Activity ( 10 minutes)

**Methodology to be used:** Structured Learning Exercise (SLE): "Yes" and "No" Placards

### **Instructions:**

Before conducting the lecture-discussion, and as a way of checking the participants' level of awareness on GAD and legislation, facilitate the following short structured learning activity:

1. Give each participant a small placard. One side of the placard reads "Yes!" while the other reads "No!"
2. Instruct the participants to flip their placards to the right side to state their opinion on whether there are legal mandates for the following:
  - ↳ Creation of a GAD focal point in each NGA.
  - ↳ LGU allocation for a GAD budget in the amount not less than 5% of total budget of each line agency.
  - ↳ Creation of a rape crisis center in every province and city.
  - ↳ Establishment of a day care center in every barangay.
  - ↳ Election of a local sectoral representative for women.
3. After reading one sentence, ask the participants to raise their placards to indicate their answers. The answers



should be "Yes" to all items. Discuss the legal mandate for each item. Thus,

- ↳ GAD focal point: EO 273 (Adoption of the Philippine Plan for Gender-Responsive Development or PPGD)
- ↳ GAD budget: EO 273 (Adoption of PPGD)
- ↳ Rape crisis center: RA 8505
- ↳ Day care center: RA 6792
- ↳ Local sectoral representatives: Constitution and LGC

4. Proceed to the lecture-discussion, using the discussion points and the visual aids.

### **Discussion Points:**

1. Major International Mandates for Gender and Development:

↳ In the international sphere, there have been many conferences and instruments that seek to address the problem of gender inequality. Some of the instruments did not originally have anything specific to say about gender equality, yet, it may be good to integrate them in the history of the legal mandates to implement gender and development.

↳ Some of the international documents that are relevant to the issue of gender equality are the following:

a) United Nations Charter

- Proclaimed gender equality as a fundamental human right

## UN Declaration of Human Rights

- No specific provision on women's rights but declares that everyone is entitled to all the rights and freedoms without distinction as to race, color, sex, language, religion political affiliation or other opinion

### c) UN Conferences on Women

- First World Conference, Mexico, 1975
  - Document: "World Plan of Action for the Implementation of the Objectives of International Women's Year"
  - Delegates urged UN to proclaim 1976-1985 as the UN Decade for Women
- Second World Conference, Copenhagen, 1980
  - Theme: Equality, Development and Peace
- Third World Conference, Nairobi, 1985
  - Adopted the "Nairobi Forward-Looking Strategies for the Advancement of Women"
- Fourth World Conference, Beijing, 1995
  - Documents adopted: Beijing Declaration and Platform for Action

#### Beijing Declaration

Expresses the determination of governments to strengthen efforts and actions for the advancement of women; by the end of the century that would result, among others, in the following:

1. economic independence of women, including employment for women
2. people-centered sustainable development;
3. peace and recognition of women's role in the peace movement;
4. elimination of all forms of violence against women and girls;
5. equal employment of human rights and fundamental freedoms for women and girls, and
6. commitment to implement the PFA, ensuring that a gender perspective is reflected in all policies and programs.

### Platform For Action (PFA)

Identifies 12 critical areas of concern, and strategies and actions that the world community must undertake to address them.

Seeks to remove obstacles to women's full and equal participation in all spheres of life, protect women's human rights, and integrate women's concerns into all aspects of sustainable development.

d) **Convention on the Elimination of All Forms of Discrimination Against Women (CEDAW)**

- Defines "discrimination against women" as any distinction, exclusion or restriction made on the basis of sex which has the effect or purpose of impairing or nullifying the recognition, enjoyment or exercise by women, irrespective of their marital status, on a basis of equality of women and men, of human rights and fundamental freedoms in the political, economic, social, cultural, civic or another field.
- The Committee on the Elimination of Discrimination against Women as the mechanism for implementation and monitoring of CEDAW. Governments must submit country reports showing compliance and/ or non-compliance with the CEDAW provisions.

e) **UN Declaration on Violence Against Women**

- Defines "violence against women" as any act of gender-based violence that results or is likely to result in, physical, sexual or psychological harm or suffering to women, including threats of such acts, coercion or arbitrary deprivation of liberty, whether occurring in public or private life.

2. **Philippine Government's Response and Action**

- ↳ The Philippines has enough documents to show that the government is committed to the advancement of

women as equal partners of men in nation-building. Some of these legal documents are:

### 1987 Constitution

- a) *Art. II, Sec. 14.* The State recognizes the role of women in nation-building, and shall ensure the fundamental equality before the law of women and men.
  
- b) *Art. XIII, Sec. 14.* The State shall protect working women by providing safe and healthy working conditions, taking into account their maternal functions, and such facilities and opportunities that will enhance their welfare and enable them to realize their full potential in the service of the nation.

### National Laws

#### a) Political Rights

- **Women in Development and Nation-Building Act (RA 7192)**
  - promotes the integration of women as full and equal partners of men in development and nation-building
  - allows women to enroll in military schools
  - allows women to take out loans, enter into contracts, engage in economic activities, even without the consent of their husbands

- Local Government Code (RA 7162)
  - provides for sectoral representation of women in LGUs
- Party List Systems Act (RA 7941)
  - provides election of party-list representatives through the party-list system, including women as a sector

b) Economic rights

- Anti-Discrimination Law (RA 6725)
  - strengthens prohibition of discrimination against women in employment, promotion and training opportunities
- Technical Education and Skills Development Act (RA 7796)
  - provides access to higher quality and efficient education and skills development as well as the representation of women in the TESDA Board (*economic and political*)
- Minimum Wage of Local Domestic Helpers and Providing Social Security for Them (RA 7655)

- determines the minimum wage of local domestic helpers and makes social security available to them
- Assistance to Women in Micro and Cottage Business Enterprises (RA 7882)
  - provides assistance to women engaging in micro and cottage business enterprises
- Migrant Workers and Overseas Filipinos Act (RA 8042)
  - authorizes granting of small loans to women for the purchase of tools or equipment for business of their choice and provides free training under TESDA

c) Violence Against Women

- Anti-Mail Order Bride Law (RA 6955)
  - declares unlawful the practice of matching Filipino women for marriage to foreign national on a mail-order basis
- Anti-Sexual Harassment Law (RA 7877)
  - declares unlawful the practice of sexual harassment in the employment, education and training environments, and provides penalty therefor
  - prescribes the adoption of policies in the establishment level

- Anti-Rape Law (RA 8353)
  - re-classifies rape from a private to a public crime  
expands the definition of rape
- Rape Victim Assistance and Protection Act (RA 8505)
  - requires all cities and provinces to have a rape crisis center, provides for assistance to rape survivors, such as medical services, legal counseling, etc.

d) Support for reproductive role of women

- Increase in Maternity Leave Benefits (RA 7322)
  - increases the maternity benefits of women workers in the private sector from 45 days to 60 days benefit equivalent (and 72 days for caesarian deliveries)
- Paternity Leave Act (RA 8187)
  - grants paternity leave of seven days with full pay to married male employee in the private and public sectors for the first four deliveries of the legitimate spouse with whom he is cohabiting
- Rooming-in and Breastfeeding Act (RA 7600)



- requires all government and private health institutions with obstetrical services to adopt rooming-in and breastfeeding practice
- Day-Care in Every Barangay (RA 6792)
  - establishes day care centers in every barangay to free women from their other activities

### Executive Issuances

- a) Adoption of the Philippine Development Plan for Women (PDPW) for 1989 – 1992 (EO 348)
  - Adoption of the Philippine Plan for Gender-Responsive Development (PPGD) for 1995 – 2025 (EO 273)
    - linked to the Medium-Term Philippine Development Plan (MTPDP), 1993 – 1998
    - Vision includes:
      - ◆ Gender equality and equity
      - ◆ Women's empowerment
      - ◆ Sustainable development
      - ◆ Peace and justice
      - ◆ Actualization of human potentials beyond basic needs
      - ◆ Democratic participation
      - ◆ Self-determination at all levels

- ◆ Respect for human rights (right to food, shelter, and a decent life)

- Strategies:

Mainstreaming GAD

- ◆ Gender-responsive process/ mechanism
- ◆ GAD Focal Points and other structures
- ◆ Training and advocacy
- ◆ Gender-responsive data base system
- ◆ GO-NGO cooperation

Economic strategies

- ◆ Gender-sensitive industry and employment planning
- ◆ Equal opportunities for training, jobs and growth
- ◆ Agrarian reform and other structural changes
- ◆ Protection of women overseas contract workers

Socio-economic strategies

- ◆ Reforming public's image of women/ media message
- ◆ Promoting the value of effective parenting, marital care, housework, child care

- ◆ Reforming policies for the workplace
- ◆ Setting up shelter and crisis centers
- ◆ Monitoring human rights

#### Addressing political and legal issues

- ◆ Developing IEC materials for the legal education of women
- ◆ Adopting gender-responsive laws, including those dealing with violence against women
- ◆ Increasing women's political participation

### **Materials Needed**

Acetates of the following international documents and national laws on GAD:

## Acetate 6

### International documents:

1. United Nations Charter
2. UN Declaration of Human Rights
3. UN Conferences on Women
  - a) First World Conference, Mexico, 1975
  - b) Second World Conference, Copenhagen, 1980
  - c) Third World Conference, Nairobi, 1985
  - d) Fourth World Conference, Beijing, 1995
    - Documents Adopted: Beijing Declaration and Platform for Action
4. Convention on the Elimination of All Forms of Discrimination Against Women (CEDAW)
5. UN Declaration on Violence Against Women

## Acetate 7

### **Philippine Government's Response and Action**

#### 1987 Constitution

1. *Art. II, Sec. 14.* The State recognizes the role of women in nation-building, and shall ensure the fundamental equality before the law of women and men.
2. *Art. XIII, Sec. 14.* The State shall protect working women by providing safe and healthy working conditions, taking into account their maternal functions, and such facilities and opportunities that will enhance their welfare and enable them to realize their full potential in the service of the nation.

#### National Laws

1. Political Rights
  - Women in Development and Nation-Building Act (RA 7192)
  - Local Government Code (RA 7162)
  - Party List Systems Act (RA 7941)
2. Economic rights
  - Comprehensive Agrarian Reform Law (RA 6657)
  - Anti-Discrimination Law (RA 6725)
  - Technical Education and Skills Development Act (RA 7796)
  - Minimum Wage of Local Domestic Helpers and Providing Social Security for Them (RA 7655)
  - Assistance to Women in Micro and Cottage Business Enterprises (RA 7882)

- Migrant Workers and Overseas Filipinos Act (RA 8042)
3. Violence Against Women
    - Anti-Mail Order Bride Law (RA 6955)
    - Anti-Sexual Harassment Law (RA 7877)
    - Anti-Rape Law (RA 8353)
    - Rape Victim Assistance and Protection Act (RA 8505)
  4. Support for Reproductive Role of Women
    - Increase in Maternity Leave Benefits (RA 7322)
    - Paternity Leave Act (RA 8187)
    - Rooming-in and Breastfeeding Act (RA 7600)
    - Increase in Maternity Leave Benefits (RA 7322)
    - Paternity Leave Act (RA 8187)
    - Rooming-in and Breastfeeding Act (RA 7600)
    - Day-Care in Every Barangay (RA 6792)

#### Executive Issuances

1. Adoption of the Philippine Development Plan for Women (PDPW) for 1989 – 1992 (EO 348)
2. Adoption of the Philippine Plan for Gender-Responsive Development PPGD) for 1995 – 2025 (EO 273)

# ***Tools for Analyzing Community Issues***

---

## **Introduction**

Having understood the mandate for local governments to address gender issues, it now becomes a challenge for local government legislators and officials to address the gender issues of the community. Likewise, it is a challenge for them to understand community issues using another perspective, the gender perspective. Hence, the tools discussed in this session become very potent in the enhancement of the participant's skills in gender advocacy.

## **Rationale**

In undertaking gender as part of their development agenda, local legislators and officials must be equipped with the skills for analyzing community issues and for understanding how they impact on women's lives. Because of their unequal status and position in society, women and men experience the same problem differently. A single solution to an issue will also affect their lives differently. It now becomes a challenge for LGUs to look at community issues through the gender lens.

The tools presented in this session are designed to break the notion that communities are always homogenous. These tools can be used in analyzing a problem or a proposed project that is seen as a solution to the problem.

## Objectives

At the end of the session, the participants should be able to:

- ↳ understand analytical tools for planning and assessment of projects that may be implemented by LGUs, and
- ↳ collectively use the tools in analyzing identified issues in the community using the gender lens.

## Core Messages

1. Analysis of community problems has a tendency to be gender-blind.
2. But because of heightened gender awareness, LGUs will discover that there are gender dimensions in local issues faced by the communities.
3. The issues may be multi-faceted, having many causes which must be collectively analyzed.
4. Resolution of these issues may require multi- disciplinary responses.



## **Activity 16**

Tools for Analyzing Community  
Issues (1 Hour)

**Methodology to be used:** Lecture-Discussion

### **Instructions:**

1. Present each tool to the participants, giving examples in the discussion points above to illustrate the use of each tool.
2. In the presentation, show each tool through an overhead projector to demonstrate its format.

### **Discussion Points:**

1. The following are just some of the tools that are found and discussed on "Two Halves Make a Whole: Balancing Gender Relations in Development," Canadian Council for International Co-operation, MATCH International Centre, Association Quebecoise des Organismes de Cooperation Internationale, Ottawa, August 1991:

#### Sexual/Gender Division of Labor

#### **Critical Questions:**

- ↳ What work do women (and girls) do (paid and unpaid)?

- ↳ What work do men (and boys) do (paid and unpaid)?
- ↳ What are the implications of this division of labor for achieving project/ program goals?
- ↳ How is work organized in the communities to be affected by the project?
- ↳ Does the project tend to reinforce or challenge the existing division of labor?

### Types of Labor

#### Critical Questions:

- ↳ What kinds of work do women and men (girls and boys) do?
- ↳ In what ways will the productive, reproductive and community work of women and men be affected by a project/ program, and in what ways will these different types of work affect a project?

#### Three Main Categories of Work

- a) *Productive*: involves the production of goods and services for consumption and trading (farming, fishing, employment and self-employment).
- b) *Reproductive*: involves the care and maintenance of the household and its members,

including bearing and caring for children, food preparation, water and fuel collection, shopping, housekeeping and family health care.

- c) *Community Work*: involves the collective organization of social events and services: ceremonies and celebrations, community improvement activities, participation in groups and organizations, local political activities, and so on.

### Harvard Analytical Framework

ACTIVITY	WOMEN/ GIRLS	MEN/ BOYS
<b>A. Production Activities</b> 1. Agriculture <ul style="list-style-type: none"> <li>• Weeding</li> <li>• Planting</li> <li>• Harvesting</li> </ul> 2. Income-generating 3. Employment 4. Others		
<b>B. Reproductive Activities</b> 1. Water-related 2. Fuel-related 3. Food preparation 4. Child-care 5. Health-related 6. Cleaning and repair 7. Market-related 8. Others		

## Differential access to and control of resources and benefits

### Critical Questions:

#### ↳ Resources:

- a) What productive resources do women and men have access to?
- b) What implications does this pattern have for program/ project activities?
- c) How can a project contribute to increasing access to and control over resources?
  - Resources can include:
    - economic or productive resources such as land, equipment, tools, labor, cash/credit, employable/income-earning opportunities
    - political resources such as representative organizations, leadership, education and information, public-sphere experience, self-confidence and credibility
    - time
  - Access is the opportunity to make use of something

**Control over a resource is the ability to define its use and impose that definition on others**

**↳ Benefits**

- a) What benefits do women and men each receive from productive, reproductive and community work, and from the use of resources?
- b) What benefits do they each have control over to use as they please?
- c) What are the implications for program/ project activities?
- d) How can women's access to and control over benefits be increased?
  - Benefits can include:
    - provision of basic needs such as food, clothing and shelter, cash and income, asset ownership, education and training, political power, prestige, status, and opportunities to pursue new interests

## Harvard Analytical Framework:

RESOURCES AND BENEFITS	ACCESS		CONTROL	
	WOMEN	MEN	WOMEN	MEN
<b>A. Resources</b> - Land - Equipment - Labor - Cash - Education - Others				
<b>B. Benefits</b> - Outside income - Asset ownership - Basic needs (food, clothing, shelter) - Education - Political power - Others				

### Influencing Factors

#### Critical Questions:

- ↳ What key factors—past, present and future— influence and change gender relations, division of work, and access to and control over resources?
- ↳ What constraints and opportunities do these factors present for promoting gender equality and the empowerment of women?

- Examples of factors:
  - □ economy, environmental conditions, legal changes, war and political crises, education, religion, the growing women's movement, and western influence.
- Look into past and present. Project the future.

Harvard Analytical Framework:

FACTOR	IMPACT	OPPORTUNITIES	CONSTRAINTS
<ul style="list-style-type: none"> <li>- Political</li> <li>- Economic</li> <li>- Cultural</li> <li>- Educational</li> <li>- Environmental</li> <li>- Legal</li> <li>- International</li> <li>- Others</li> </ul>			

Condition and position

Critical Questions:

- ↳ How and to what extent do project/program activities and organizational policies contribute to improving the conditions of women and men?
- ↳ How and to what extent do they contribute to improving women's position in society?
  - *Condition:* refers to women's material state; their immediate sphere of influence; can refer to the kind of work that they do, the needs

they see for themselves and for their children, where they live, etc.

- Position: refers to women's social and economic standing relative to men. It is measured, for example, by male/ female disparities in wages and unemployment opportunities, participation in legislative bodies, vulnerability to poverty and violence, etc.

Development projects and programs affect the condition of women and men's lives differently. A water supply project may significantly improve the condition of women's lives, but make little impact on men's. The situation may be reversed in agricultural projects with significantly negative impact on women. For example, a project that introduces a new fertilizer may make women's lives harder by increasing the labor of weeding, a traditionally female task.

Development projects and programs can affect the position of women. The effect can be negative, if the existing areas of activity and control are eroded or eliminated. The effect can be positive if the women are seen as active change agents. Example: a water supply project which involves women as pump caretakers, technicians, community water committee members and health educators may have a positive effect on women's condition and position. But if the project only involves them as pump users, the project may not improve women's condition or position.



Development projects have tended to focus on women's condition, aiming to improve their ability to carry out traditional roles and responsibilities.

Indicators of improvements in women's position are usually less obvious than improvements in condition. Since they are more qualitative than quantitative, they are also harder to measure. Some indicators are:

- Increased acceptance by women and men of women as community decision-makers
- Greater personal and economic independence and self-confidence for women
- New, more visible, and more effective women's organizations
- More women in education and training programs
- Improved health of women and children
- Improvements in women's legal status
- A decline in violence against women
- Increased women's control over their own fertility
- Reduced institutional discrimination and bias against women
- Increased public awareness of women's issues

## **Materials Needed**

- Acetates on the bullet items raised in the discussion points above
- Overhead projector

## Activity 17

Workshop on the Gender Tools (1 hour and 30 minutes)

**Methodologies to be used:** Application of the tools on caselets, Discussions and Workshop

### Instructions:

1. Divide the participants into two groups.
2. Each group will be given a caselet to analyze using any or all of the tools discussed above.
3. The two (2) caselets are the following:

#### *Situation 1:*

Kaunlaran is a second-class municipality Mindanao. It is relatively prosperous as it has very rich natural resources. Many of its residents live in the coastal barangays and earn their living through fishing. Others are factory workers in the tuna-canning factories that were established by the local and foreign capitalists. Salaries provided in these factories are of minimum-wage level.

Mayor Sumulong is the newly-elected local chief executive of the municipality and would like to mobilize communities to take part in her "Angat Kaunlaran" project, aimed at promoting adult literacy. In the implementation of the project, she found out that only a few are interested in her project. Of those who showed

interest in participating in the project, many are male barangay officials.

Questions:

1. What is the gender dimension of the problem, if any?
2. How can Mayor Sumulong identify the gender issues in these coastal barangays? What are the relevant questions that she needs to answer?
3. How can Mayor Sumulong mobilize the coastal barangays for her project?

Situation 2:

Kasanyangan is a newly-established city in the Visayas. Because it is new, the city still has little resources. Mayor Manuel is determined to make his city a progressive one.

After a briefing from the Chief of Police, the Mayor found out that there are complaints coming from women who are beaten by their husbands and common-law spouses. Aside from the complaints, the police also informed the Mayor that there are many other unreported cases that they hear about. The Mayor met with the barangay captains to discuss the problem. Many said that they cannot do much because the women refuse to be helped. When the Mayor called the women from the communities, the women seemed to be extremely shy to be talking to the Mayor. They remained silent when asked about the violence.

## Questions:

1. What is/ are the identifiable problem(s) in the communities?
  2. What are the possible strategies in addressing this/ these problem(s)?
  3. How can Mayor Manuel get the support of the different sectors of the community in addressing the problem/s?
4. Give the groups one (1) hour to answer the questions using any of the tools that they think are useful in answering the questions to their assigned case. Instruct them to document their answers on manila paper for reporting later on.
- ↳ After one hour, call the groups into plenary. Ask each group to present their discussion of the answers and the use of the tools in arriving at their answers. In the presentation of the groups, they should be able to:
- a) Answer the guide questions in their caselets.
  - b) Present the tools that they used in answering the questions.
  - c) Explain why they chose these tools (over others) in answering the questions in their caselets.
- 5) Synthesize the reports and emphasize the following points:

- a) In the usual way of doing things, problem-analysis tends to be gender-blind. Women's experiences of the problems, their views on the proposed solutions, their contributions to the perpetration of the problems as well as to the solutions are not given enough consideration.
- b) Because of their differences in status and position, women and men are affected by problems in different ways.
- c) The tools can be useful in putting a gender perspective in the analysis of community problems and proposed strategies.
- d) Hence, proposed solutions to these community problems or issues must also consider the impact not only on the people of the community as a whole, but also, specifically, on the women in the community.

## **Materials Needed**

- Acetates on which the caselets are written
- Overhead projector
- Manila paper and pentel pens
- Masking tape and scissors

# Harvard Analytical Framework

ACTIVITY	WOMEN/ GIRLS	MEN/ BOYS
<b>A. Production Activities</b> 1. Agriculture <ul style="list-style-type: none"> <li>• Weeding</li> <li>• Planting</li> <li>• Harvesting</li> </ul> 2. Income-generating 3. Employment 4. Others		
<b>B. Reproductive Activities</b> 1. Water-related 2. Fuel-related 3. Food preparation 4. Child-care 5. Health-related 6. Cleaning and repair 7. Market-related 9. Others		

**Acetate 9**

**Harvard Analytical Framework:**

RESOURCES AND BENEFITS	ACCESS		CONTROL	
	WOMEN	MEN	WOMEN	MEN
<b>A. Resources</b> - Land - Equipment - Labor - Cash - Education - Others				
<b>B. Benefits</b> - Outside income - Asset ownership - Basic needs (food, clothing, shelter) - Education - Political power Others				

<b>C. Benefits</b> - Outside income - Asset ownership - Basic needs (food, clothing, shelter) - Education - Political power - Others				
--	--	--	--	--

**etate 10**

<b>FACTOR</b>	<b>IMPACT</b>	<b>OPPORTUNITIES</b>	<b>CONSTRAINTS</b>
- Political - Economic - Cultural - Educational - Environmental - Legal - International - Others			



## Acetate 11

### *Situation 1:*

Kaunlaran is a second-class municipality in Mindanao. It is relatively prosperous as it has very rich natural resources. Many of its residents live in the coastal barangays and earn their living as fishers. Others are factory workers in the tuna-canning factories that were established by the local and foreign capitalists. Salaries provided in these factories are of minimum-wage level.

Mayor Sumulong is the newly-elected local chief executive of the municipality and would like to mobilize communities to take part in her "Angat Kaunlaran" project, aimed at promoting adult literacy. In the implementation of the project, she found out that only a few are interested in her project. Of those who showed interest in participating in the project, many are male barangay officials.

### Questions:

1. What is the gender dimension of the problem, if any?
2. How can Mayor Sumulong identify the gender issues in these coastal barangays? What are the relevant questions that she needs to answer?
3. How can Mayor Sumulong mobilize the coastal barangays for her project?

## Acetate 12

### *Situation 2:*

Kasanyangan is a newly-established city in the Visayas. Because it is new, the city still has little resources. Mayor Manuel is determined to make his city a progressive one.

From a briefing from the Chief of Police, the Mayor found out that there are complaints coming from women who are beaten by their husbands and common-law spouses. Aside from the complaints, the police also said that there are many other unreported cases that they hear about. The Mayor met with the barangay captains to discuss this problem. Many said that they cannot do much because the women refuse to be helped. When the Mayor called the women from the communities, the women seemed to be extremely shy to be talking to the Mayor. They remained silent when asked about the violence.

### Questions:

1. What is/ are the identifiable problem(s) in the communities?
2. What are the possible strategies in addressing this/ these problem(s)?
3. How can Mayor Manuel get the support of the different sectors of the community in addressing the problem/s?

# ***Gender Responsive Local Legislation and Policy***

---

## **Introduction**

After imparting to the participants the need for gender analysis in examining and responding to community issues, the participants should now be prepared to proceed to the discussion on how to translate their proposed responses into governmental policy issuances, both legislative and executive. This session is one of the core topics of the training. The session will provide the participants with concrete handles to ensure that laws and issuances issued are valid or legal. More importantly, it will provide the participants guidelines in enacting gender-responsive laws and executive issuances. Also included as part of the session is the discussion on practical advocacy strategies to ensure the enactment of gender-responsive laws and policies.

## **Rationale**

Before the participants can proceed to the drafting of legislative and executive issuances embodying the gender agenda, they must understand the parameters for governmental rule-making. One of the basic skills that legislators and local executives must possess is the ability to draft, pass, or implement legal, valid and binding ordinances, resolutions or various orders and issuances.

As officials of the people, they should enact laws and issuances that are responsive to the issues and sensitive to the needs of their constituency. Gender is an aspect that may easily be presumed to be a constant consideration in legislation and policy-making because laws must apply equally to all. In reality, however, gender-related concerns have been sidelined and considered "soft issues" in governance. To be truly effective, legislators and executives should develop not only the skill to draft laws and issuances but also the consciousness to proceed with every enactment using relevant gender-sensitive standards. To do this, it is important that the participants understand the basic procedure for local rule-making and how advocacy efforts can be undertaken within this process.

## Objectives

At the end of the of the session, the participants should be able to:

- ↳ explain the basic principles that should guide the drafting and enactment of gender-responsive legislation and policy issuances;
- ↳ comprehend the practical and strategic gender needs of men and women as basis for legislation and policy formulation;
- ↳ understand the guidelines for gender-responsive legislation and policy formulation;

- ↳ explain the differences between an ordinance and a resolution;
- ↳ explain the steps in the preparation and enactment of gender-responsive legislation and policies, and
- ↳ internalize the entry points where gender advocates may influence the process of legislation making and policy formulation towards the enactment of gender-responsive ordinance/resolution and executive issuances, including the lobbying techniques which local officials and other gender advocates may employ.

## **Core Messages**

1. There are basic guidelines in local legislation and policy-making which should be considered by local legislators and policy makers in formulating valid gender-responsive legislation and policy issuances.
2. An important consideration in gender-responsive policy measures is the understanding of sexual division of labor that gives rise to different needs of men and women.
3. Women's needs may be practical (day-to-day, refers to reproductive needs) or strategic (long-term, addresses the issue of women's subordination to men in society).

4. To address women's subordination, interventions should aim for women's empowerment and gender equality.
5. Proposed legislation and policies should be formulated based on gender analysis.
6. The enactment of an ordinance/resolution consists of several steps.
7. In each step or process of drafting legislative or executive issuances, different forms of advocacy may be pursued to ensure a gender-responsive measure from government.
8. The participation of women and other gender advocates in the enactment of a proposed ordinance, resolution or administrative issuance is necessary in GAD mainstreaming.

## **Activity 18**

Guidelines in Local Legislation and  
Policy Formulation  
(1 hour and 30 minutes)

**Methodologies to be used:** Game, Lecture and  
Discussion

### **Instructions:**

1. Introduce the topic by saying that the training will now move from the discussion of the gender agenda into the

translation of this agenda into concrete governmental action, i.e. through gender-responsive executive and legislative issuances. After this, tell the participants that for these governmental policies to effectively address gender concerns, they must first be valid. Explain that there are certain basic principles that must be followed in the enactment of local legislation and in the making of executive issuances. Failure to follow these principles may invalidate a piece of local legislation or an executive issuance.

2. Announce to the participants that to start the discussion of these basic guidelines, the participants will play a game called, "TEPOK-BUHAY".

*Note: There must be at least three (3) facilitators for this game.*

3. Divide the participants into three (3) groups.
4. Ask the members of each group to stand or sit side by side, with each among forming a single line. The group members must be facing the facilitators.
5. Give each group a set of 10 cards. Each card will have a letter written on it. The letters will spell out the words, TEPOK and BUHAY. As much as possible, each group member will have only one card. If there are less than 10 member in each group, some members will have two cards instead of one.
6. Once the members of the group have their cards, ask the

members to practice raising their cards to spell the words TEPOK or BUHAY.

7. Explain the instructions for the game:

- ↳ The facilitator will read examples of ordinances passed by some Sanggunians (please see the Annex for the questions). Some of the ordinances are valid and some are not.
- ↳ After each question is read twice, the facilitator shall ask, "Is the ordinance valid? TEPOK o BUHAY?"
- ↳ Once this question is asked, the participants should immediately raise the cards to spell the answer which they think is correct. If they think the ordinance is valid, the answer is "buhay"; if they think the ordinance is invalid, the answer is "tepok".
- ↳ A group that gets the correct answer AND the correct spelling of the answer (TEPOK or BUHAY) will get a point.
- ↳ The facilitators will only recognize the answer that first appears from each group (based on the first cards immediately raised by the participants). An answer that is misspelled is marked wrong.

8. After explaining the instructions, start the game by asking the first question.

9. As soon as the participants raise their cards, immediately write down on the board the groups' answers as spelled. Expect erroneously spelled answers (BEPOK, TUHAY, TEPO, BEPHAY, etc.) especially during the early part of the game when the participants in each group would not have any coordination with each other. *Note: For this*



*purpose, there must be one facilitator assigned to each group so that the group's answer (first set of cards raised) will be immediately read and written on the board.*

10. Once all the answers to the question have been written on the board, read the question again and ask the participants what they think the answer is. Evoke a brief discussion on the answers given.
11. After the discussion, give the correct answer and explain it briefly. Mark the correct answers given by the participants (only those correctly spelled) with a check.
12. Repeat the procedure for all questions.
13. After all questions have been asked and answered, proceed to the lecture-discussion using the outline found above in the "Discussion Points".
14. In discussing the guidelines for enacting local legislation, refer back to the questions in the game whenever the discussion becomes relevant to such questions.

## **Discussion Points**

1. Basis of the Power to Pass Ordinances
2. Ordinance and Resolution Compared

### 3. Substantive Limitations on Ordinance-Making

- ↳ Ordinance should be in accordance with the Constitution.
- ↳ *Ordinance* should be in accordance with national law.
- ↳ Ordinance is effective only within the territorial jurisdiction of the LGU.
- ↳ Ordinance is always repealable.
- ↳ Ordinance should not be contrary to public policy
- ↳ Ordinance should not be vague.
- ↳ Ordinance should not be discriminatory.
- ↳ Ordinance may regulate but may not prohibit trade.
- ↳ Ordinance should be reasonable and not oppressive.

### 4. Other Basic Principles Related to Ordinance-Making

- ↳ All ordinances are presumed valid.
- ↳ Ordinances require approval by a higher Sanggunian.
- ↳ The Judiciary has the ultimate authority to judge validity of ordinances.

### 5. Definition of Policy Issuance

### 6. Principles in Policy Formulation

- ↳ Nature of Task of Policy Formulation
- ↳ Principle of Non-delegation of Legislative Power
- ↳ Test of Validity of Delegation.

- a) Completeness of the Ordinance
- b) Presence of a Standard

## 7. Types of Policy Issuances

↳ In the performance of his/her functions, the Local Chief Executive may issue the following:

- a) Executive Orders - Acts providing for rules of a general and permanent character in the implementation or execution of a law or ordinance.
- b) Administrative Orders – Acts which relate to particular aspects of governmental operations in pursuance of his duties as administrative head.
- c) Proclamations – Acts fixing a date or declaring a status or condition of public moment or interest, upon the existence of which the operation of a specific law or regulation is made to depend.
- d) Memorandum Orders – Acts on matters of administrative detail or of subordinate or temporary interest which only concern a particular officer or office of the local government.
- e) Memorandum Circulars – Acts on matters relating to internal administration, which the Local Chief Executive desires to bring to the attention of all or some of the departments, agencies, bureaus or offices of the local government, for information or compliance.
- f) Memorandum – A brief note or informal letter containing directives, instructions, or information requiring appropriate action.

## **Questions and Answer Key for Tepok – Buhay:**

*Note: The following questions involve hypothetical cases. The ordinances mentioned are not actual ordinances enacted by the local government unit stated in the questions.*

- 1. The municipality of Gumaca, Quezon passed an ordinance creating a Council of Women. In its desire to protect this Council of Women from possible abolition by local government officials in the future, the sanggunian included in the ordinance a provision saying that the ordinance shall be "irrepealable" meaning that it cannot be repealed.*

*Is this provision in the ordinance valid or not? Tepok or Buhay?*

**Answer: TEPOK- AN ORDINANCE IS ALWAYS REPEALABLE.** If an ordinance contains a provision that states that it is irrepealable, this should be considered invalid since it seeks to limit the power of subsequent Sanggunians to legislate freely.

- 2. The Municipality of Dinalupihan, Bataan passed an ordinance prohibiting the formation of a Labor Union in its territory.*

*Is the ordinance valid? Tepok or Buhay?*

**Answer: TEPOK - AN ORDINANCE CANNOT VIOLATE THE CONSTITUTION.** The ordinance violates the Constitutional guarantee to labor for self-organization and collective bargaining.

3. *Intending to prohibit the display of calendars with nude pictures of female models, the municipality of Nasipit, Agusan del Norte passed an ordinance prohibiting the display in public places of "sexy calendars," without defining this term.*  
*Is the ordinance valid? Tepok or Buhay?*

Answer: TEPOK- AN ORDINANCE SHOULD NOT BE VAGUE. Among other possible objections, the ordinance in this case does not specify what constitutes "sexy calendars." It is, hence, vague.

4. *The City of Ormoc passed an ordinance suspending the implementation of the Anti-Sexual Harassment Act in its territory.*  
*Is the ordinance valid? Tepok or Buhay?*

Answer: TEPOK- AN ORDINANCE CANNOT VIOLATE A NATIONAL LAW. An ordinance cannot contravene a national law which in this case is the Anti-Sexual Harassment Act.

5. *The province of Guimaras passed an ordinance prohibiting the entry into its territory of mangoes coming from other places in order to protect its mangoes from possible infestation.*  
*Is the ordinance valid? Tepok or Buhay?*

Answer: BUHAY- AN ORDINANCE IS EFFECTIVE ONLY WITHIN THE TERRITORY OF THE LOCAL GOVERNMENT UNIT THAT ENACTED IT. This ordinance does not violate

this principle because its effectivity is still limited inside the territory of Guimaras, even if it may affect things or persons that come from outside.

6. *Barangay 8 in Legazpi, Albay passed an ordinance ordering the construction of a monument for Juan De Cuchillo, a resident who, during his lifetime, was known to have committed a number of abuses against women and a convicted rapist.*

*Is the ordinance valid? Tepok or Buhay?*

Answer: TEPOK- AN ORDINANCE SHOULD NOT BE CONTRARY TO PUBLIC POLICY. The act of the Sanggunian seems to glorify the act of committing violence against women. While the ordinance may not be violating any law or constitutional provision, it is clearly contrary to public policy.

7. *The municipality of San Jose, Antique passed an ordinance establishing and allocating funds for a program of informal education for mothers who stay in their home taking care of the household. Male residents complain that the informal education program is discriminatory.*

*Is the ordinance valid? Tepok or Buhay?*

Answer: BUHAY- AN ORDINANCE SHOULD NOT BE DISCRIMINATORY. While the ordinance makes a classification (between males and females), the classification in this case is not discriminatory since it rests on a reasonable distinction that intends to cater to the special needs of the mothers.

8. *According to the Land Use and Zoning Ordinance of Cebu*

*City, beer houses or night clubs can only be established within a designated portion of its territory. Outside such designated area , beer houses and night clubs cannot operate.*

*Is the ordinance valid? Tepok or Buhay?*

Answer: BUHAY - AN ORDINANCE MAY REGULATE, BUT MAY NOT PROHIBIT TRADE. In this case, the ordinance seeks merely to regulate and not prohibit the operation of beer houses and night clubs.

9. *In its desire to protect minors, especially women, Caloocan City passed an ordinance imposing the penalty of imprisonment on students below the age of majority who will be caught cutting classes, i.e. roaming around the city during supposed class hours.*

*Is the ordinance valid? Tepok or Buhay?*

Answer: TEPOK- AN ORDINANCE SHOULD BE REASONABLE AND NOT OPPRESSIVE. Even if the purpose of the ordinance is laudable and the prison term is within the prescribed term in the Local Government Code, the means and the measures are too oppressive for violators.

10. *Barangay Masagana of Quezon City passed an ordinance imposing the penalty of imprisonment for men who will utter sexually offensive language or make sexually offensive gestures directed at a woman.*

*Is the ordinance valid? Tepok or Buhay?*

Answer: TEPOK- IF AN ORDINANCE IMPOSES A PENALTY, IT SHOULD BE IN CONFORMITY WITH SET

LIMITS. A barangay cannot impose the penalty of imprisonment. It may only impose fines under the Local Government Code.

## Materials Needed

- TEPOK-BUHAY Cards (sets of ten cards, the number of sets depending on the number of participants), measurement is six inches by eight inches. Preferably cut from illustration board. Sample:



- Black/ white board and chalk/ board marker

## Activity 19

Criteria for Gender-Responsive Local Legislation and Policy Formulation  
(1 hour and 30 minutes)

**Methodologies to be used:** Lecture-Discussion

### Instructions:

1. Introduce the topic by stating that after ensuring that legislation and issuances are valid, the next step is the preparation of said documents. Tell the participants that this stage is very crucial because it will determine what issue the measure will focus on, as well as the specific responses that the local government will undertake to address the issue.



2. The session will discuss steps involved in the preparation of legislation and issuances. Stress to the participants that while the process undertaken in each step may look difficult, this is the only way that gender-responsive enactments may be ensured. It is important that the trainer give examples for each area that may be ambiguous to the participants. Some experiences shared by the participants may be used as examples.

## **Discussion Points:**

*Source: Main materials from the two-volume guide book, "Toward a Gender-Responsive Legislation" (NCRFW, 1999) and adapted for this training*

It is very important to come up with valid legislation and policies. To achieve development, policies and laws should respond to the needs and situation of the people being governed.

To effectively come up with gender-responsive legislation and policies, the following steps need to be undertaken:

1. Research
  2. Formulation of Proposed Measure
  3. Review and Amendments
1. Policy preparation or research. In brief, there are three main areas that must be completed:

↳ Issue/ problem identification

Problem identification. To identify the issue or

problem that will be addressed, situation analysis should be undertaken. General sources of information should always be considered. Equally important as basis for issue determination is the situation prevailing in the local government unit concerned. In determining the issues that need legislative or policy intervention, local executives can refer to the following:

- a) Studies or researches on the issue/ problem conducted by national agencies, academic institutions specializing on gender studies, or women's groups
- b) Statistics or pertinent data available at the National Statistics Office, National Commission on the Role of Filipino Women, DSWD, DOLE, etc. Data from the area should also be collated from local sources, e.g. Social Work Office, police, hospitals
- c) Commitments made by the national government through international instruments
- d) Consultations with multi-sectoral groups involved in gender issues. In these meetings, current state of issues will surface and prioritization of issues can be done.
- e) The development agenda or plan of the local government. Ideally, they should include gender-related concerns. Considerations of the identified gender-related plans should also be done.

- f) Specific requests for legislation or policy submitted to the legislator or official by his or her constituency on a particular issue.

### Prioritizing Issues

- a) Consultations with women's groups and other groups or stakeholders involved in gender issues, can determine which among the issues need urgent consideration.
- b) Recent events within or outside the local government unit that may have caught the attention or concern of the public.
- c) Bias of the legislator or policymaker may also determine the issue that will be given attention.

### ↳ Data-gathering and analysis

#### Determining and gathering needed data

- a) Relevant data should be available, such as: magnitude of the issue, women or groups of women affected by the issue; its manifestations, its root causes, recommended responses, pertinent human rights documents, existing or relevant national laws on the issue, international obligations of the government pertaining to the issue.

Analyzing Data and Situation. The following are some guide questions:

- a) What are the economic, political, social or other factors that cause the issue or problem? What are its root causes? What are its immediate causes? If the issue is the promotion of a certain right of women, e.g. right to sit as sectoral representative in the Sanggunian, what are the barriers to its exercise or realization?
- b) What is the magnitude of the problem? Where is it most prevalent? How many women are affected? Are all women similarly affected by it, or are there groups of women more affected? If yes, which groups are these and what accounts for the differential effect?
- c) What are the problems underlying gender-based assumptions or differences about women and men? How do these assumptions result in or contribute to gender inequalities or women's marginalization?
- d) Are there laws pertinent to the issue or problem? How do they address the issue? Do they reflect the above mentioned gender-based assumptions?
- e) Do institutions like the media, religion, family or State contribute in aggravating or reinforcing the issue or problem? If yes, how?
- f) What rights of women are involved? What rights of women are violated because of the issue or problem?

- g) What specific human rights treaties or other documents covering the particular issue or problem has been ratified or adopted by the government? How do they view the issue or problem?

↳ Issue/ problem definition

Defining the issue. Some guide questions:

- a) After clarifying the situation and its context, how can the issue or problem be stated in a way that will best reflect the situation, especially considering its gender dimension? Consider here women's definitions or formulation of the issue or problem.
- b) Does the definition take into account and accurately reflect the experiences of women? Does it reflect the male view of the issue or problem, and underpin gender-based assumptions?
- c) What potential objections, on legal or other grounds, can be raised against a gender-sensitive definition of issues or problems? How can those objections be countered using human rights standards and citing other commitments of the government?

2. Formulation of the legislative or executive proposal

Setting the objectives of the proposal. Some guide questions:

- a) What are the different aspects of the issue or problem that should be addressed by the legislation or policy?
- b) What practical and immediate needs of women pertinent to the issue or problem should be met by the proposal? Are they true for all women? If no, what are the practical needs specific to certain women or groups of women that the proposal should consider?
- c) What strategic needs of women pertinent to the issue should be addressed?
- d) What other gender concerns should be addressed?
- e) What standards set by treaties and other documents *are* pertinent to the issue or problem?

Identifying measures to achieve the objectives. Some guide questions:

- a) How can the various aspects of the issue or problem be addressed?
- b) What measures can be integrated into the proposal that will respond to the pertinent practical needs of women? What specific measures may be necessary to meet the specific needs of certain women or groups of women?
- c) What measures are necessary to respond to the pertinent strategic needs of women?

- d) What measures should be provided to respond to other gender concerns related to the issue or problem?
- e) Choosing from alternatives to achieve the same outcome, which will benefit the most number of women? Which will best address the gender-based concerns pertinent to the issue?

### Formulating the Proposed Measure

- a) Included as a consideration at this point are the previous discussions on the validity of the measure and the form it shall take. Some guide questions: Is the language used gender-sensitive? What practical measures should be integrated to ensure the implementation of the proposal once passed?

## 2. Review and Amendments. The following areas should be examined:

### Definition of the issue and objective

- a) What gender-based assumptions underlie the definition of the problem? Does it assume certain stereotypes about men and women with respect to capacities, roles, etc.?
- b) What are its assumptions about women's experience or situation? Are they valid for all women? Or are they true only for some women or groups of women? What are the other premises of the proposal? Are they valid?

- c) Is the definition of the issue reflective of the male view?
- d) Does the analysis of the problem include examination of its gender-based causes? Have the pertinent rights of women been violated or the human rights standards been taken into account?

#### Proposed measures to achieve the objectives

- a) Do the proposed measures address the practical concerns or women pertinent to the issue?
- b) Do they respond to women's strategic concerns that are relevant to the issue? Or do they reinforce gender-based biases against women or perpetuate inequalities against them?
- c) Are the measures proposed appropriate to the needs of all women? Or, are there measures that will have to be provided for certain women or groups of women?

### Materials Needed

- Transparencies

### Activity 20

Steps in the Preparation and Enactment of Gender- Responsive Legislation and Policy (1 hour and 30 minutes)



## **Methodologies to be used:** Games and Lecture-Discussion

### **Instructions:**

1. Introduce this activity by saying that after knowing the basic guidelines and criteria in making valid gender-responsive legislation and executive issuances, it is now necessary to have a review of the steps for the passage of ordinances and resolutions and the promulgation of executive issuances.
2. Tell the participants that as a start, they will play a game patterned after the game called "Snakes and Ladders".
3. Divide the participants into four (4) groups.
4. After the participants have grouped themselves into four groups, present the gameboard that depicts the local legislative process. A sample gameboard is attached.
5. Explain that the objective of the game is to travel from the starting point to the finish line by going through the different steps in the preparation and enactment of an ordinance. The number of steps will be determined by the number that the group will get by throwing a die. The group that finishes first shall win the game.
6. Explain the contents of the gameboard. A box in the gameboard with a question mark represents a step in the legislative process, which the participants will identify when their group reaches the said box. A box with a

star represents a "surprise," which will be revealed only when the group reaches the said box.

7. The game shall then be played as follows:

- a) The four groups shall first roll the die to determine the order of their turns. The group that gets the highest point shall go first. Each group shall be represented on the gameboard by a small cartolina cut-out.
- b) The first group begins the game by identifying the first step in the legislative process. The group is given 10 seconds to give its answer. Failure to give the proper answer within the time allotted will mean forfeiture of its turn.
- c) If a group identifies the correct step, it shall then be allowed to roll the die and to make the number of steps on the gameboard equivalent to the number that the group gets from the die. If the group reaches another box with a question mark, then it shall again identify the step in the legislative process represented by the box before it can proceed. As long as the group is able to identify the correct step, it shall be allowed to roll the die anew and continue the process. If the number in the die would move the group beyond a box bearing a question mark, the group shall not be allowed to advance at all if it is not able to correctly identify the correct step in local legislation.

- d) The facilitator shall remove the cover and reveal the step if a group has correctly identified it.
  - e) If in a turn, the group lands on a box without any mark, the other groups will then take their turns in rolling the die and moving on the board.
  - f) If a group lands on a box with a question mark and fails to identify the correct step, the group shall remain in the box and not be allowed to move. The other groups shall then take their turns.
  - g) The group that first reaches the end wins.
8. After the game, summarize the steps in the local legislative process.
  9. Clarify that a resolution does not necessarily go through these same steps, unless the rules of the sanggunian require the resolution to go through these steps.
  10. After discussing the local legislative process, proceed to the discussion of local policy formulation by the local chief executive.
  11. In each step, identify the advocacy measure that can be taken, as cited in the Discussion Points below. Encourage the participants to share their experiences relevant to the topic.

## Discussion Points:

### 1. Local Legislation

↳ Like the central government, each local government unit has a legislative body called the *sanggunian*. It is through their respective *sanggunian* that the local governments exercise their law-making powers. A *sanggunian* can pass two types of legislative issuances: the Ordinance and the Resolution.

↳ Ordinance vs. Resolution - An Ordinance is the local law passed by a local legislative body that has a more or less general and permanent nature. It prescribes a rule that must be followed by the constituents and by those persons who come within the territorial jurisdiction of the local government concerned. A Resolution, on the other hand, is a formal expression of the sentiment of the local legislative body. It is generally of a temporary nature and usually covers proprietary functions and private concerns.

It is very important to ensure that gender concerns are considered in every step undertaken by the *sanggunian*. In discussing the steps prescribed by law, the venues to advocate for gender issues are also discussed.

↳ Steps in local legislation:

a) Sponsorship - The proposal will be submitted or sponsored by a member of the local legislative body. The proposal may be the product of

consultations with the sectors affected or it may be crafted by the sponsor him/herself.

It is crucial to identify a sponsor who understands gender issues. Ideally, the sponsor should be an advocate. However, considering that gender-sensitive legislators are few, a sympathetic legislator is the next best option. Women's groups or advocates can present to the legislator a draft of the proposal which the legislator may file or may amend. Be sure to provide the sponsor all the necessary background information that will help him/her understand the issue. These may include statistics, case analysis, case outlines, available legislation on the issue both of national and local application. If possible, the sponsor should adopt the advocates' proposal in its totality.

- b) First Reading - On First Reading, the title of the bill will be read.
- c) Referral to Appropriate Committee – After the first reading and without debating on the merits of the bill, the presiding officer shall refer the bill to the appropriate committee of the *sanggunian* for further study. The Chairperson of the concerned committee may call public hearings on the bill, if necessary.

Although the sponsor of the proposed measure may be any member of the *sanggunian*, it may be helpful to choose as sponsor the chair of the committee where the measure will be assigned.

This way, the measure has greater chances of being scheduled for hearing. At the same time, group/s will have greater access to the sponsor/chairperson because they are more familiar with each other due to past meetings about the proposed measure. Participation of advocates to hearings called for by the committee is more or less assured.

- d) Second Reading - On Second Reading, the committee which conducted the preliminary study of the bill will submit its report to the *sanggunian*. It is at this point that debates on the merits of the bill will ensue. The bill will then be submitted for voting. If the *sanggunian* votes against the bill, the bill is defeated.

The advocates can participate in the debate by acting as consultants of the sponsor. They may sit in the panel that will provide support to the sponsor and his/her staff. Possible issues that will be raised on the floor can be pre-deliberated with the sponsor and answers to said issues may be drafted.

- e) Third Reading - On Third and Final Reading, the *sanggunian* will make its final vote on the bill. If approved by the *sanggunian*, the bill will be submitted to the Local Chief Executive for his/her signature. If the *sanggunian* votes against the bill, the bill is defeated.

The advocates may mobilize other women and supporters and be present during the voting. This is to show the *sanggunian* the presence of support

for the issue and the clamor to pass the particular measure.

- f) Approval by Local Chief Executive - The bill finally becomes an ordinance if:
- It is signed or approved by the Local Chief Executive.
  - The Local Chief Executive does not make any action on the bill within 15 days (in the case of the Province) or 10 days (in the case of the City or Municipality). Due to the Local Chief Executive's inaction, the bill shall become an ordinance as if the Local Chief Executive has signed it.
  - The Local Chief Executive vetoes (disapproves) the bill but the veto was overridden by the vote of  $\frac{2}{3}$  of all the members of the *sanggunian* concerned.
- g) Publication - The ordinance becomes effective on the date stated in the ordinance or after ten (10) days from the date a copy of the said ordinance is posted on a bulletin board at the entrance of the provincial capitol or city, municipal, or barangay hall, as the case may be, and in at least two (2) other conspicuous places in the local government unit concerned. The Secretary of the *sanggunian* concerned shall see to it that the ordinance is posted not later than five (5) days after its approval.

#### Review of Ordinances

- a) Review by the Sangguniang Panlalawigan - Within three (3) days after the approval, the secretary of

the Sanggunian Panlungsod or Sangguniang Bayan shall forward to the Sangguniang Panlalawigan for review, copies of approved ordinances and public investment programs formulated by the local development councils. If the Sangguniang Panlalawigan finds that such an ordinance or resolution is beyond the power conferred upon the Sangguniang Panlungsod or Sangguniang Bayan concerned, it shall declare such ordinance or resolution invalid in whole or in part. If the Sangguniang Panlalawigan takes no action within thirty (30) days after submission of such an ordinance or resolution, it shall be presumed consistent with law and therefore valid.

- b) Review by the Sangguniang Panlungsod or Sangguniang Bayan - Within ten (10) days after its enactment, the Sangguniang Barangay shall furnish copies of all barangay ordinances to the Sangguniang Panlungsod or Sangguniang Bayan concerned for review as to whether the ordinance is consistent with the law and with city/municipal ordinances. If the Sangguniang Panlungsod or Sangguniang Bayan, as the case may be, fails to take action on barangay ordinances within thirty (30) days from receipt thereof, it shall be deemed approved. If the Sangguniang Panlungsod or Sangguniang Bayan, as the case may be, finds the barangay ordinances inconsistent with a national law or city or municipal ordinance, the sanggunian concerned shall, within thirty (30) days from receipt thereof, return the same with its comments and recommendations to the



Sangguniang Barangay concerned for adjustment, amendment, or modification; in which case, the effectivity of the barangay ordinance is suspended until such time as the revision called for is effected.

## 2. Executive Issuances

- ↳ General powers of Local Chief Executives - The Chief Executive Officers of the local governments have the following general powers:
  - a) Exercise general supervision and control over all programs, projects, services, and activities of the local government;
  - b) Enforce all laws and ordinances relative to the governance of the unit and the exercise of its corporate powers;
  - c) Implement all approved policies, programs, projects, services and activities of the local government unit;
  - d) Initiate and maximize the generation of resources and revenues, and apply the same to the implementation of development plans, program objectives and priorities;
  - e) Ensure the delivery of basic services and the provision of adequate facilities;
  - f) Exercise other powers and perform other functions as may be prescribed by law or ordinance.

The Local Chief Executive also acts as the overall administrator and general manager of the local government unit. Thus, s/he is in-charge of the human resources management and development of the local government's personnel complement.

- ↳ Review of Executive Issuances - The Governor shall review all executive orders promulgated by the component city or municipal mayor within his/her jurisdiction. The city or municipal mayor shall review all executive orders issued by the punong barangay within his/her jurisdiction. In all instances of review, the Local Chief Executive conducting the review shall ensure that such executive orders are within the powers granted by law and in conformity with provincial, city, or municipal ordinances. If the governor or the city or municipal mayor fails to act on said executive orders within thirty (30) days after their submission, the same shall be deemed consistent with law and therefore valid.

Gender advocates may submit specific proposals for gender-responsive issuances to the local government. Said proposals may be coursed through strategic offices or people in the local government, such as a sympathetic legislator, the administrator, planning officer or budget officer. It is very important that in providing proposals, the proponents supply all necessary data and background information to facilitate the adoption and approval of the measure.

# ***Drafting of Ordinances and Executive Issuances***

---

## **Introduction**

The session provides some guidance on how to craft ordinances, resolutions and executive issuances that are gender-sensitive and responsive.

## **Rationale**

The session aims to help participants prepare ordinances, resolutions and executive issuances that are gender-sensitive and responsive. This integrates some principles is gender-responsive legislation and policy formulation.

## **Objectives**

At the end of the session, the participants should be able to:

- ↳ Draft ordinances, resolutions, and executive issuances.
- ↳ Apply their knowledge of the principles of gender-responsive legislation and policy formulation in drafting, ordinances, resolutions and executive issuances.

## **Activity 21**

Workshop: Drafting of Ordinances, Resolutions, and Executive on Issuances ( 2 hours)

**Methodology to be used:** Workshop

### **Instructions:**

1. The facilitator shall divide the participants into two (2) groups: one for the local legislators and another for the executive officials. Each group shall further be divided into sub-groups according to their local government unit, if possible. If this is not possible, the participants may be divided into sub-groups of 3-5 members, provided that the legislators and the executive officials shall not mix in one group.
2. Instruct the participants that each sub-group of legislators will draft one ordinance and one resolution while each sub-group of executive officials will draft one executive order and another executive issuance of their choice.
3. The facilitator will remind the participants that the legislative and executive issuances must be gender-responsive.

4. Each sub-group will decide the subject and contents of their legislative or executive issuance.
5. Instruct the participants that they have one hour to discuss and draft their issuances. The issuances must be written on manila paper.
6. The facilitator must be available to assist the participants whenever necessary.

### **Materials Needed:**

- Manila paper
- Pentel pens
- Masking tapes

## **Activity 22**

### First Presentation and Critiquing of Draft Issuances

**Methodology to be used:** Presentation and Discussion (1 hour)

### **Instructions:**

1. There must be at least two (2) facilitators - one facilitator for the legislators and another for the executive officials. The legislators shall form one workshop group and the executive officials shall form another group.

2. The facilitator (of each major group) will ask the sub-groups (per LGU or 3-5 members) to present their draft issuances.
3. After each presentation, the facilitator will ask the sub-group that presented the issuance to explain the gender issue that the group tried to address through the issuance.
4. The facilitator shall ask the sub-group to explain how the issuance would effectively respond to and address the issue that they have identified.
5. The facilitator will also ask the sub-group to share with the other participants the difficulties that it encountered while drafting the issuance.
6. The facilitators shall then ask the other participants who do not belong to the sub-group that presented the issuance to comment on the draft issuance.
7. Instruct the participants that the comments must focus on the substance and format of the provisions and not on the grammar or writing style.
8. After the participants have presented their comments, the facilitator may add his/her observations.

## **Materials Needed:**

- Manila paper
- Pentel pens
- Masking tapes

## **Activity 23**

Second Presentation and Critiquing  
of the Draft Issuances  
(1 hour)

**Methodology to be used:** Presentation and  
Discussion

## **Instructions:**

1. Prior to this activity, there must be a short break. During the break, the draft issuances prepared by the participants will be displayed at the session/plenary hall for the participants' viewing. The facilitator shall instruct the participants to read the draft issuances prepared by their colleagues.

The facilitator shall also ask the two major groups (legislators and executive officials) to appoint one reporter who will present a summary of the issuances drafted by the sub-groups, the gender issues that have been identified and how the issuances are intended to address these issues, and the difficulties encountered by the participants in drafting the issuances.

2. The participants will be asked to reconvene as one big group, i.e., the legislators and the executive officials will be together.
3. The reporter for each major group shall then be requested to present a summary of the group's workshop.
4. After the presentation, the facilitator may ask the other participants (especially those belonging to the other major group) to comment or ask questions.
5. After the presentations of the two major groups, the facilitator shall then synthesize the reports and the results of the workshop.

### **Materials Needed:**

- Manila paper
- Pentel pens
- Masking tapes



5. The facilitator must ask the groups to write their plans on manila paper, and appoint a reporter for the presentation of the plans.
6. To facilitate the presentation of the plans, the facilitator may suggest the following format:

Issue	Activity	Time frame	Person-in-charge

7. The participants shall be given 45 minutes for the workshop after which, each group shall present its plans to the rest of the participants.
8. The facilitator may ask questions to clarify some points in the plans presented by the participants.
9. After the presentations, the facilitator shall then make a synthesis of the plans reported by the groups.

### **Materials Needed:**

- Manila paper
- Pentel pens

# ***Guide to Planning***

---

## **Introduction**

The session gives the participants opportunity to share their plan of action for mainstreaming gender in local legislation and policy formulation.

## **Rationale**

With the concepts and principles on gender covered during the three-day activities, the participants must now be given the chance to apply their learnings and insights by preparing a plan of action for gender mainstreaming, appropriate for their respective localities.

## **Objectives**

At the end of the session, the participants should be able to:

- ↳ Formulate a preliminary plan of action for gender-responsive legislation and policy formulation.
- ↳ Discuss with their colleagues in the same local government unit the immediate activities that can be conducted within their locality.

## **Activity 24**

### **Planning Workshop**

**Methodology to be used:** Small Group Discussion and Workshop  
(45 minutes)

#### **Instructions:**

1. The facilitator shall divide the participants according to their local government units. This time, legislators and executive officials of the same local government unit will be in the same group. If the composition of the participants will not allow this kind of grouping (if, for example, all participants come from the same local government units), alternative groupings can be used.
2. The facilitator shall ask the participants to review the gender issues that they have identified as pervasive in their localities (they have previously identified these).
3. With these issues in mind, the participants shall discuss the possible activities that they think should be conducted in their localities in order to ensure gender-responsive legislation and policy formulation.
4. The participants may identify specific ordinances or resolutions that must be enacted or passed, or executive issuances that must be issued, to effectively address the gender issues in their localities.

5. The facilitator must ask the groups to write their plans on manila paper, and appoint a reporter for the presentation of the plans.
6. To facilitate the presentation of the plans, the facilitator may suggest the following format:

Issue	Activity	Time frame	Person-in-charge

7. The participants shall be given 45 minutes for the workshop after which, each group shall present its plans to the rest of the participants.
8. The facilitator may ask questions to clarify some points in the plans presented by the participants.
9. After the presentations, the facilitator shall then make a synthesis of the plans reported by the groups.

**Materials Needed:**

- Manila paper
- Pentel pens

# ***Training Plan***

---

## ***Objectives of the Training:***

*At the end of the training, the participants should be able to:*

- 1. Arrive at a common understanding and appreciation of GAD mainstreaming;*
- 2. Understand their roles as local legislators and local government officials in integrating gender in local legislation and policy formulation;*
- 3. Appreciate the tools for gender analysis, in aid of gender-responsive legislation and policy-formulation.*

## Annex A: Training Plan

Topic	Objectives	Core Messages	Methodology	Time Allotted
<b>Day One</b>				
<b>I. Introduction</b>				
Introduction	<p>At the end of the session, the participants should be able to:</p> <ol style="list-style-type: none"> <li>1. Have an overview of the training objectives and design;</li> <li>2. Introduce themselves and get to know the facilitators and the other participants, and</li> <li>3. Express their expectations from the training (in terms of content and methodology), from the facilitators, and from co-participants.</li> </ol>		<ul style="list-style-type: none"> <li>- Introduction of the facilitators and participants, surfacing of expectations: GAME</li> <li>- Presentation of the project objectives and component/ training schedule: OHP presentation</li> </ul>	1 hour and 30 minutes

Topic	Objectives	Core Messages	Methodology	Time Allotted
<p><b>II. Basic Gender-Sensitivity</b> Sex and Gender</p>	<p>At the end of the session, the participants should be able to:</p> <ol style="list-style-type: none"> <li>1. Define sex and gender and understand the distinctions between the two, and</li> <li>2. Understand the impact of sexual division of labor on gender relations.</li> </ol>	<ol style="list-style-type: none"> <li>1. Most of the commonly considered "natural" gender-based differences are <i>actually</i> societal constructs that are used in discriminating against women.</li> <li>2. The differences between women and men should be used as bases for development agenda and projects that will push for gender equality and women's empowerment.</li> </ol>	<ul style="list-style-type: none"> <li>- Metacard exercise: characteristics of men and women</li> <li>- Lecture-discussion on concepts of sex, vis-a-vis gender, gender roles and socialization</li> </ul>	2 hours

Topic	Objectives	Core Messages	Methodology	Time Allotted
Manifestations of Gender Bias	<p>At the end of the session, the participants should be able to:</p> <ol style="list-style-type: none"> <li>Identify the different manifestations of gender bias, and</li> <li>Provide concrete examples of manifestations of every identified gender bias.</li> </ol>	<ol style="list-style-type: none"> <li>Acts of gender bias are prevalent and can be categorized as: marginalization, subordination, multiple burden, stereotyping, violence against women and other personal effects on women.</li> <li>The bias is culturally rooted and can be changed.</li> <li>Women and men are both actors and stakeholders in the quest for development.</li> <li>Both women and men have a stake in working for gender equality.</li> </ol>	<ul style="list-style-type: none"> <li>Film-showing: "Impossible Dream"</li> <li>Discussion of gender roles, sexual division of labor and gender relations</li> </ul>	2 hours 30 minutes
Personal Reflection Session	<p>At the end of the session, the participants should be able to:</p> <p>Reflect on their personal experiences of gender discrimination</p>	<p>Experiences of gender bias differ from person to person</p>	<ul style="list-style-type: none"> <li>Reflection session</li> <li>Sharing within dyads</li> </ul>	2 hours



Topic	Objectives	Core Messages	Methodology	Time Allotted
Day Two Conceptual Framework	<p>At the end of the session, the participants should be able to:</p> <ol style="list-style-type: none"> <li>1. Appreciate the concept of Gender equality as a human rights issue, different development approaches and gender equality and women's empowerment framework (GEWEF); and</li> <li>2. Understand the conceptual framework of integrating GAD in local legislation and policy formulation, including the LGU bureaucracy.</li> </ol>	<ol style="list-style-type: none"> <li>1. The principle of gender equality has been recognized internationally as an issue of human rights</li> <li>2. A just and sustainable society should ensure that the processes for policy making promotes gender equality and empowerment.</li> <li>3. Local legislation and policy formulation are venues for ensuring gender equality and women's empowerment.</li> <li>4. The processes involved in legislation and policy-making should be responsive to the promotion of gender equality and women's empowerment.</li> <li>5. Gender equality and women's empowerment is are interwoven in all the steps of legislation and policy making.</li> </ol>	-Lecture discussion	1 hour 30 minutes

Topic	Objectives	Core Messages	Methodology	Time Allotted
<b>III. Women and Governance</b> Women and Governance	<p>At the end of the session, the participants should be able to:</p> <ol style="list-style-type: none"> <li>1. Understand the basic structures and powers of the national and local governments;</li> <li>2. Identify the venues for women's participation in local governance; and</li> <li>3. Identify structures and principles that will encourage or enhance gender integration in local governance.</li> </ol>	<ol style="list-style-type: none"> <li>1. Knowledge of the national government's powers, structures and mechanisms is necessary to understand how the exercise of governmental powers and functions can address gender concerns.</li> <li>2. Given the local governments' special role and broadened powers under a decentralized system of governance, the different governmental structures and decision-making processes within the local government unit are important targets of advocacy efforts for GAD.</li> <li>3. As local government officials, the participants are in a position to effect changes towards gender equality through gender-responsive local legislation and policy formulation.</li> </ol>	<ul style="list-style-type: none"> <li>- Question and answer game</li> <li>- Lecture-discussion</li> </ul>	Game : 30 minutes Lecture: 1 hour

Topic	Objectives	Core Messages	Methodology	Time Allotted
<p><b>IV. Building a Gender Agenda</b>            Legal Mandates for GAD</p>	<p>At the end of the session, the participants should be able to:</p> <ol style="list-style-type: none"> <li>1. Define the government's commitments to the international community to respond to gender issues ;</li> <li>2. Enumerate the constitutional provisions, local laws, the Philippine Plan for Gender-Responsive Development (PPGD) and other legislation intended to address gender inequality, and</li> <li>3. Distinguish the critical role of the participants in addressing gender inequality through gender-responsive local legislation and policy formulation.</li> </ol>	<ol style="list-style-type: none"> <li>1. The national and local governments are legally bound to respond to gender inequality through laws, policies and programs.</li> <li>2. As local government officials, the participants are in a position to effect changes towards gender equality through gender-responsive local legislation and policy formulation.</li> <li>3. LGUs are powerful mechanisms for successful endeavors in GAD mainstreaming.</li> </ol>	<p>- Lecture-discussion</p>	<p>1 hour</p>

Topic	Objectives	Core Messages	Methodology	Time Allotted
<p>Tools for Analyzing Community Issues</p>	<p>At the end of the session, the participants should be able to:</p> <ol style="list-style-type: none"> <li>Understand analytical tools for planning and assessing projects that may be implemented by LGUs, and</li> <li>Collectively use the tools in analyzing identified issues in the community using the gender lens.</li> </ol>	<ol style="list-style-type: none"> <li>There are gender dimensions in local issues faced by the communities.</li> <li>The issues may be multi-faceted, having many causes which must be collectively analyzed.</li> <li>Resolution of these issues may require multi-disciplinary responses.</li> <li>Analysis of community problems has a tendency to be gender-blind.</li> </ol>	<ul style="list-style-type: none"> <li>Workshop: Application of the tools to caselets</li> </ul>	<ul style="list-style-type: none"> <li>Lecture/discussion: 1 hour</li> <li>Workshop including reporting: 1 hour 30 minutes</li> </ul>

Topic	Objectives	Core Messages	Methodology	Time Allotted
<p>V. Translating Agenda into Policy</p> <p>Gender-Responsive Local Legislation and Policy Formulation</p> <p>Session I</p>	<p>At the end of the session, the participants should be able to:</p> <ol style="list-style-type: none"> <li>1. Explain the basic principles that should guide the drafting and enactment of gender-responsive legislation and policies.</li> </ol>	<ol style="list-style-type: none"> <li>1. There are basic guidelines in legislation and policy-making which should be considered by local legislators and policy.</li> </ol>	<ul style="list-style-type: none"> <li>- SLE: TEPOK-BUHAY (for void and valid ordinance/ resolution)</li> </ul>	<ul style="list-style-type: none"> <li>- Tepok Buhey and discussion of basic principles in local legislation and policy formulation: 1 hour 30 minutes</li> </ul>

Topic	Objectives	Core Messages	Methodology	Time Allotted
<b>Day Three</b> Gender-Responsive Local Legislation and Policy Formulation Session II	<ol style="list-style-type: none"> <li>2. Comprehend the practical and strategic gender needs of men and women as basis for legislation and policy formulation.</li> <li>3. Understand guidelines for gender-responsive local legislation and policies.</li> <li>4. Explain the differences between ordinance and resolution.</li> <li>5. Explain the steps in the preparation and enactment of gender-responsive legislation and policies.</li> <li>6. Internalize the entry points where gender advocates may influence the process of legislation making and policy formulation towards the enactment of gender-responsive ordinance/ resolution and executive issuances, including the lobbying techniques which local legislators and other gender advocates may employ.</li> </ol>	<ol style="list-style-type: none"> <li>2. The sexual division of labor gives rise to different needs for men and women.</li> <li>3. Women's needs may be practical (day-to-day, refers to reproductive needs of need) or strategic (long-term, addresses the issue of women's subordination in society).</li> <li>4. To address women's subordination, interventions should aim for women's empowerment and gender equality.</li> <li>5. Proposed legislation and policies should be based on gender analysis.</li> <li>6. The enactment of an ordinance/ resolution consists of several steps.</li> <li>7. Successful advocacy for a proposed ordinance, resolution or executive issuance requires several strategies and methodologies.</li> </ol>	<ul style="list-style-type: none"> <li>- SLE: Critique of an ordinance using the criteria and other points discussed in the session</li> <li>- SLE Legislative procedure: "Snakes and Ladders"</li> <li>- Lecture-discussion</li> </ul>	<ul style="list-style-type: none"> <li>- Snakes and Ladder and discussion of procedure, forms, gender responsive criteria and venues for advocacy in local legislation and policy formulation: 3 hours</li> </ul>

Topic	Objectives	Core Messages	Methodology	Time Allotted
	<p>7. Present the form of ordinances, resolutions and administrative issuances.</p>	<p>8. The participation of women and other gender advocates in the enactment of a proposed ordinance, resolution or administrative issuance is necessary in GAD mainstreaming.</p>		
<p>Formulating Ordinances and Resolutions *</p>	<p>At the end of the session, the participants should be able to:</p> <ol style="list-style-type: none"> <li>1. Draft a sample ordinance that is based on gender analysis;</li> <li>2. Critique draft ordinances and resolutions prepared by the participants, using the gender lens;</li> <li>3. Apply their knowledge of the principles of gender-responsive legislation and policy formulation in drafting, ordinances, resolutions and executive issuances;</li> </ol>		<ul style="list-style-type: none"> <li>- Workshop: Drafting an ordinance and resolution</li> <li>- Plenary presentation and critiquing</li> </ul>	<ul style="list-style-type: none"> <li>- Drafting workshop: 2 hrs.</li> <li>- Mini-plenary: 2 hrs.</li> <li>- Main Plenary: 1 hr.</li> </ul>

Topic	Objectives	Core Messages	Methodology	Time Allotted
Formulating Administrative Issuances*	<p>4. To provide the participants with the opportunity to draft gender-responsive administrative issuances, and</p> <p>5. To provide the participants the opportunity to analyze their policies and projects using gender lens.</p>		<p>- Workshop: drafting executive issuances</p> <p>- Presentation of draft executive issuances and critiquing</p>	<p>- Drafting workshop: 2 hrs.</p> <p>- Mini-plenary: 2 hrs.</p> <p>- Main Plenary: 1 hr.</p>
<b>Day Four</b>				
<b>VI. Planning</b>				
Action Planning	<p>At the end of the session, the participants should be able to:</p> <ol style="list-style-type: none"> <li>1. Formulate their preliminary plan of action for gender-responsive legislation and policy formulation; and</li> <li>2. Discuss with their colleagues in the same LGU the immediate activities that can be conducted within their locality.</li> </ol>		<p>- Workshop: Action planning per LGU (combined legislators and executive officials)</p> <p>- Plenary Presentation</p>	1 hour 30 minutes
<b>VII. Closing</b>				
Evaluation				



Topic	Objectives	Core Messages	Methodology	Time Allotted
Closing Ceremonies			<ul style="list-style-type: none"> <li>- Closing Remarks from the DILG representative</li> <li>- Awarding of Certificates of Participation</li> </ul>	1 hour

\* At this point, the participants will be divided into two— one group for the local legislators and another for executive officers. The participants will convene again as one big group for the presentation of the summary of outputs and discussions in the two sub-groups.

\*\*The participants shall be grouped according to their municipalities/ cities for the action planning. Thereafter, each group shall present their plans to the plenary.

Assistant Secretary Austere A. Panadero  
Chairperson, DILG GAD Focal Point

**Project Management Committee**

- Leticia Sanchez - *Vice President*  
Philippine Public Safety College
- Teresita M. Mistal - *Director*  
Bureau of Local Government Development
- Monina Cecilia R. Penales - *Director*  
Administrative Service
- Nelda C. Leda - *Assistant Director*  
National Barangay Operations Office
- Vilma A. Mama - *Accountant IV*  
Financial Management Service

**Project Management Team**

*(Integrating GAD in the Local Legislation and Policy Formulation  
Modules of DILG)*

Project Manager : Monina Cecilia R. Penales  
Administrative Service

Members

Melody C. Bautista - *Teresita T. Daguman*  
*Planning Service* - *Office of Project Development Services*

Blesilda Rachel F. Paule - *Priscella B. Mejillano*  
*Bureau of Local Government Supervision* - *Bureau of Local Government Development*

Reinelda C. Raffiñan - *Hilda F. Gaurino*  
*National Barangay Operations Office* - *Administrative Service*

Angelina T. Layugan - *Lilia A. Catindig*  
*Administrative Service* - *Administrative Service*

Herminia S.J. Salazar  
*Administrative Service*

**Project Staff**

Lucita L.V. Dela Peña - *Kristine B. Laborte*  
Ma. Lizeth S. Caraballos - *Danilo S. Cahigan*  
Leonilo G. Varon

